

**Waltron L.L.C. AQUALERT®
DIVISION**

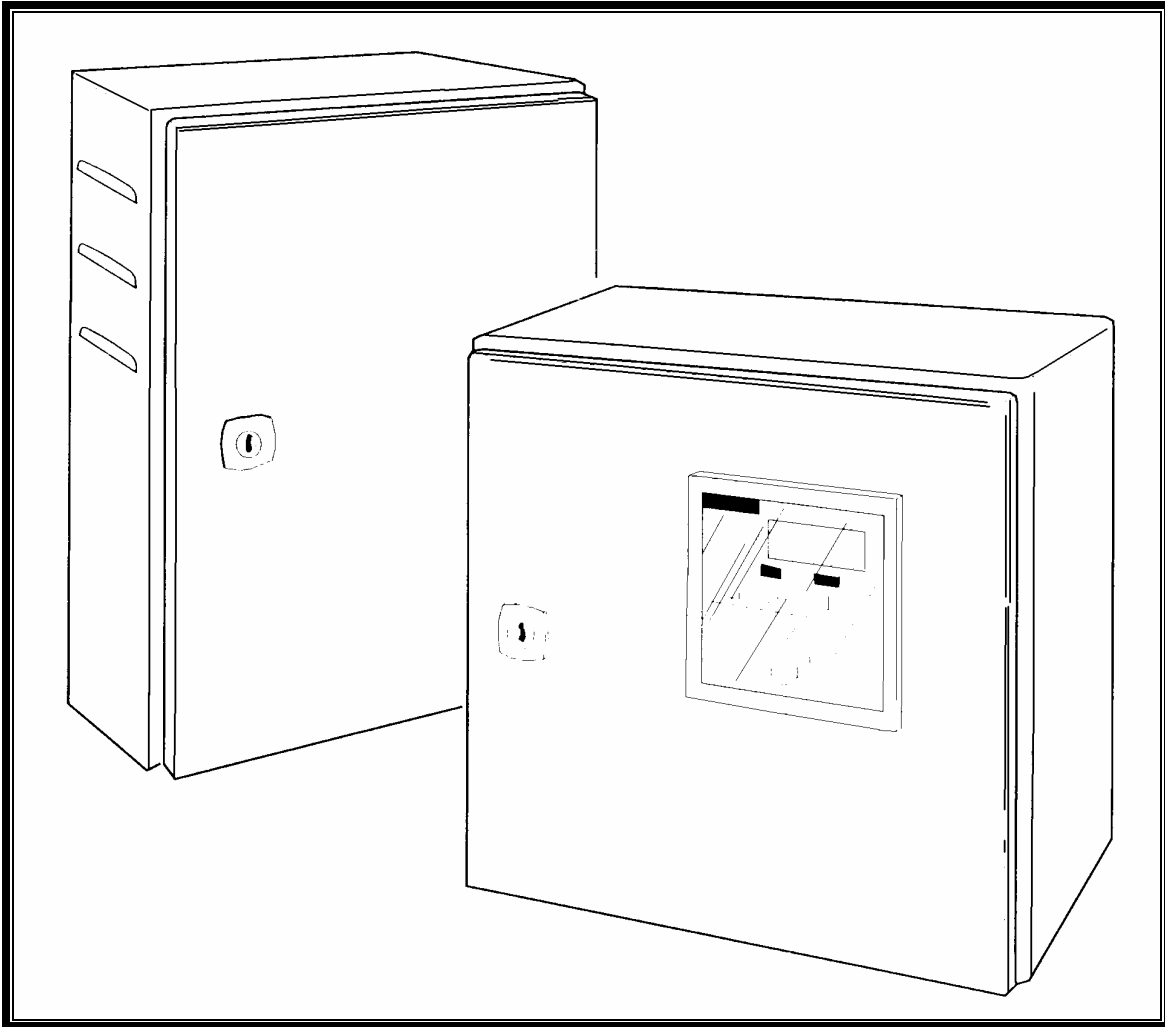

**μAI-9060 SERIES
OXYGEN MONITOR
INSTRUCTION MANUAL**

TABLE OF CONTENTS

1	INTRODUCTION.....	3
1.1	GENERAL.....	3
1.2	DESCRIPTION.....	3
1.2.1	<i>SENSOR UNIT.....</i>	<i>3</i>
1.2.2	<i>TRANSMITTER UNIT.....</i>	<i>3</i>
2	INSTALLATION.....	5
2.1	MOUNTING OF THE UNIT.....	5
2.1.1	<i>LOCATION AND LAYOUT.....</i>	<i>5</i>
2.1.2	<i>SENSOR UNIT.....</i>	<i>5</i>
2.1.3	<i>TRANSMITTER UNIT.....</i>	<i>6</i>
2.2	SAMPLE REQUIREMENTS.....	7
2.3	EXTERNAL PIPE CONNECTIONS.....	7
2.3.1	<i>INLET.....</i>	<i>7</i>
2.3.2	<i>DRAIN.....</i>	<i>7</i>
2.4	ELECTRICAL CONNECTIONS.....	8
2.4.1	<i>SENSOR UNIT.....</i>	<i>8</i>
2.4.2	<i>TRANSMITTER UNIT.....</i>	<i>10</i>
2.5	ANCILLARY EQUIPMENT.....	13
2.5.1	<i>RECORDERS.....</i>	<i>13</i>
2.5.2	<i>RANGE INDICATION.....</i>	<i>13</i>
3	START UP.....	15
4	OPERATION.....	17
4.1	SENSOR UNIT.....	17
4.2	TRANSMITTER UNIT.....	18
4.2.1	<i>ELECTRONIC CHASSIS.....</i>	<i>18</i>
4.2.2	<i>FRONT PANEL CONTROLS.....</i>	<i>19</i>
4.2.3	<i>PRINTED CIRCUIT BOARD.....</i>	<i>21</i>
4.2.4	<i>ALARMS, DEAERATED WATER SYSTEM.....</i>	<i>23</i>
4.2.5	<i>ALARMS, OXYGENATED WATER TREATMENT SYSTEM.....</i>	<i>23</i>
4.2.6	<i>ATMOSPHERIC PRESSURE COMPENSATION.....</i>	<i>24</i>
4.2.7	<i>SAMPLE TEMPERATURE.....</i>	<i>24</i>
5	CALIBRATION PROCEDURE.....	25
6	MAINTENANCE.....	26
6.1	SCHEDULED SERVICING.....	26
6.2	UNSCHEDULED SERVICING.....	26
6.2.1	<i>REPLACEMENT OF THE SENSOR.....</i>	<i>26</i>
6.3	SHUT DOWN PROCEDURE.....	28
6.3.1	<i>SENSOR UNIT.....</i>	<i>28</i>
6.3.2	<i>TRANSMITTER UNIT.....</i>	<i>28</i>

TABLE OF CONTENTS

6.4	SIMPLE ELECTRONIC CHECK	28
6.5	MAINTENANCE	29
6.6	CURRENT INPUT (μ A) DISPLAY READING.....	29
7	SPARE PARTS	31
7.1	RECOMMENDED SPARE PARTS	31
7.2	SENSOR UNIT	31
7.3	TRANSMITTER UNIT	31
8	SPECIFICATION.....	32
8.1	REMOTE RANGE.....	32
8.2	INSTALLATION INFORMATION	32
8.3	POWER SUPPLY	33
8.4	POWER SUPPLY	33
8.5	CASE PROTECTION.....	33
9	OPERATOR'S NOTE.....	34
10	OUR COMMITMENT TO OUR CUSTOMERS.....	35
11	OBSERVING SAFETY.....	36
12	WARRANTY AGREEMENT	37
13	CHECK-LIST OF MATERIALS.....	39

1 INTRODUCTION

1.1 GENERAL

The μ AI-9060 is a microprocessor-controlled on-line monitor for measuring dissolved oxygen in deaerated waters, e.g. boiler feed water. Four ranges are available: 0 to 20ppb, 0 to 200ppb, 0 to 2ppm and 0 to 20ppm. Range change is automatic.

The system consists of two discrete units, the electronics control section (transmitter unit) and the liquid handling section (sensor unit). The units can be mounted side by side or up to 325 feet (100m) apart.

1.2 DESCRIPTION

1.2.1 SENSOR UNIT

The Liquid Handling System features an airtight flow cell housing a disposable oxygen sensor which can be changed simply and rapidly when exhausted. Calibration is achieved by draining the flow cell and exposing the oxygen sensor to air. This is carried out automatically and involves no manual operation. The flow cell is self cleaning and designed to prevent air bubble entrapment and minimize particle deposition around the sensor.

This flow cell incorporates a temperature sensor for thermal compensation and for thermal protection of the oxygen sensor, diverting the sample to waste if its temperature should exceed 131°F (55°C).

1.2.2 TRANSMITTER UNIT

The microprocessor electronics section performs three main functions: it interprets and displays a reading of dissolved oxygen received from the sensor unit, controls the calibration sequence and provides the various outputs to remote equipment.

The display is a seven segment L.E.D. type indicating the level of dissolved oxygen and also providing information on the operating mode of the instrument. It informs the operator when it is in the calibration mode, when the sample is too hot and when the sensor is nearing the end of its life.

Two concentration alarm points are available, which are set up by the operation of push-buttons on the monitor front panel. The desired

alarm values are displayed by the readout when the respective push-button is depressed.

Calibration can be manually initiated when required or set to automatically occur every seven days. The oxygen partial pressure, and hence the sensor current, in air is a function of the atmospheric pressure. Before a calibration routine is initiated, the relevant atmospheric pressure can be programmed into the monitor by the use of push-buttons on the monitor front panel. This introduces a correction factor into the final calculation of dissolved oxygen concentration.

The customer programmable information is retained for a period of up to ten years in power down conditions by means of an internal battery.

2 INSTALLATION

2.1 MOUNTING OF THE UNIT

2.1.1 LOCATION AND LAYOUT

Both units should be mounted in a clean, vibration free location avoiding direct radiant heat, sunlight and drafts. Areas containing chlorinating equipment should be avoided.

The sensor unit should be mounted no more than 33 feet (10m) from its associated sample cooler. The transmitter may be mounted next to or up to 325 feet (100m) away from the sensor unit.

2.1.2 SENSOR UNIT

The sensor unit consists of a metal case which houses the liquid handling equipment. This equipment is mounted on a panel that is secured to the back of the case with four M6 captive bolts. Holes in the case for wall mounting the unit are suitable for 1/4" diameter bolts. Sufficient space must be left in front of the case for access.

FIGURE 2.1 SENSOR UNIT DIMENSIONS AND INTERCONNECTION POSITIONS

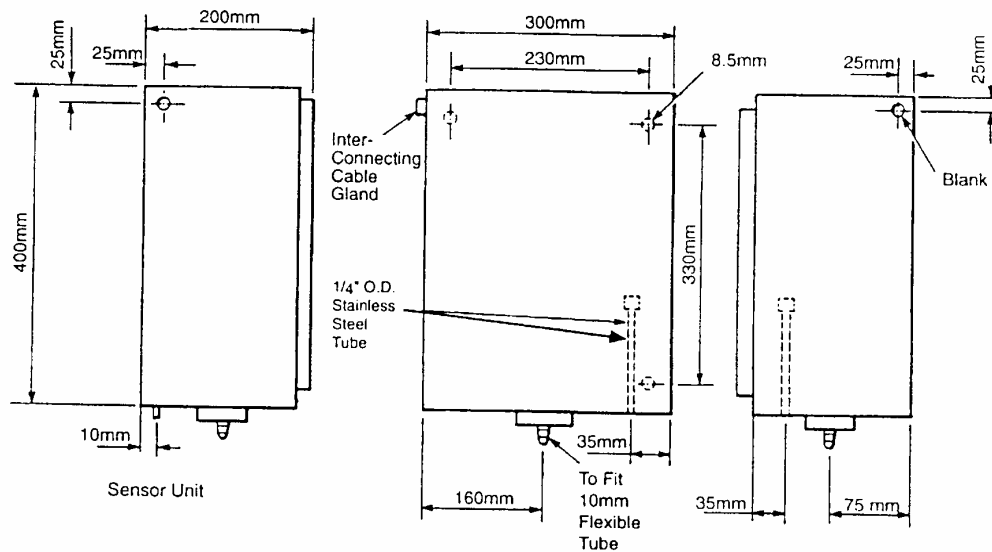

2.1.3 TRANSMITTER UNIT

The transmitter unit consists of a metal case of similar construction to the sensor case with a chassis unit supporting circuit boards and other electrical sub-assemblies. Wall mounting is by four ¼" diameter bolts on 230mm X 230mm centers - see Figure 2.2.

FIGURE 2.2 TRANSMITTER DIMENSIONS AND INTERCONNECT POSITIONS

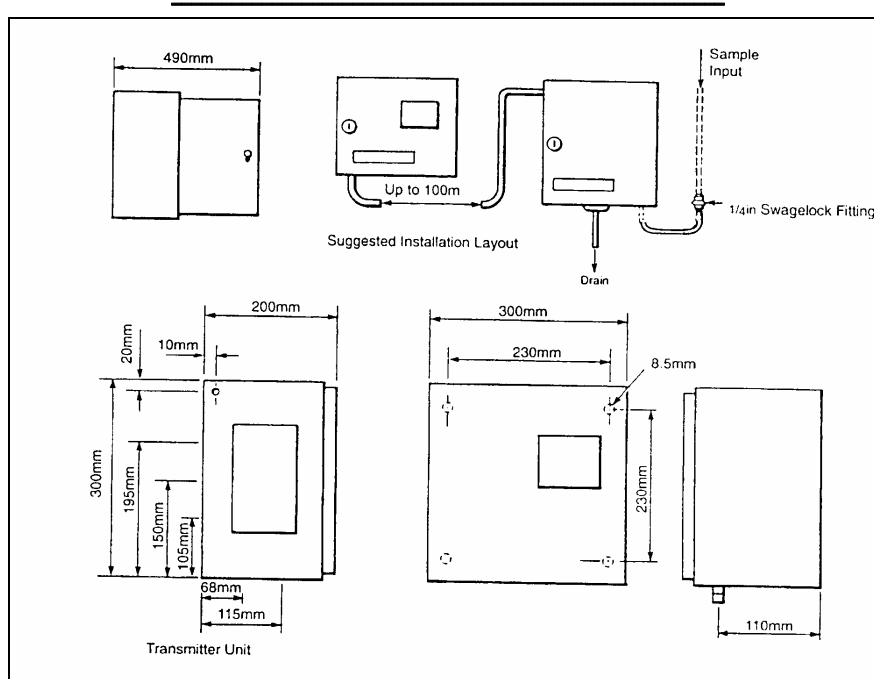

For access to wall mounting holes remove the chassis unit as follows:

- ✓ Unlock the door and open fully.
- ✓ A small coin may be used to release the front panel by turning the four black fasteners by ¼ turn in either direction.
- ✓ Hold front panel with two fingers through slot at left side. Ease front panel forward over the range switch knob.
- ✓ Remove any safety ground (earth) bonding leads attached to the metal case.
- ✓ Release the captive screws securing the chassis assembly to the back of the case and remove the chassis.

The door of the case is equipped with a lock and a window to observe the display.

On the left hand side of the case are six holes for the acceptance of liquid tight strain relief fittings suitable for the cables carrying the alarm signals, and other signal outputs.

2.2 SAMPLE REQUIREMENTS

⊗Warning. The maximum pressures and temperatures specified must not be exceeded.

Where pressure reducing equipment is being used, a pressure relief valve should be installed between the sample point and the sample inlet to the monitor to ensure maximum safety.

The sample should be brought to the temperature and pressure suitable for measurement - see SPECIFICATION.

If necessary use sample cooling and pressure reducing equipment.

2.3 EXTERNAL PIPE CONNECTIONS

2.3.1 INLET

Sample should be connected to the sensor unit by means of stainless steel tubing of 1/4" outside diameter. Connect this to the sample inlet coupling on the right hand side of the bottom of the case.

The inlet tubing should have walls thick enough to withstand the highest sample pressure and the pipe lengths should be kept short to minimize the possibility of loss of oxygen.

An isolation valve (not supplied) is necessary in the sample inlet line to the sensor unit.

2.3.2 DRAIN

The drain from the cup at bottom of the sensor unit in the case is a hose barb fitting suitable for 3/8" bore plastic or rubber tubing. The monitor does not affect the sample except to expose it to air and hence

the sample effluent can be led to the clean drain for return to the feedwater supply.

2.4 ELECTRICAL CONNECTIONS

⚠ Warning.

- ✓ Although certain instruments are fitted with internal fuse protection, a suitably rated external protection device, e.g. fuse or miniature circuit breaker (m.c.b.), must also be fitted by the installer.
- ✓ Before making any connections, make sure that the power supply and high voltage power operated control circuits are switched off.
- ✓ The equipment operates on a.c. voltage electricity; suitable safety precautions must always be taken to avoid the possibility of electric shock.

2.4.1 SENSOR UNIT

The liquid tight strain relief fitting for the connection cable within the sensor unit is situated at the top right hand side of the case, but may be transferred to the opposite side if this is more convenient - see Fig. 2.1.

A seven foot (2m) length of 8-way overall screened cable is normally supplied for interconnecting the sensor and transmitter units; longer lengths may be ordered separately. The interconnecting cable is routed to a terminal block in a junction box on the inside of the case door - see Figure 2.3.

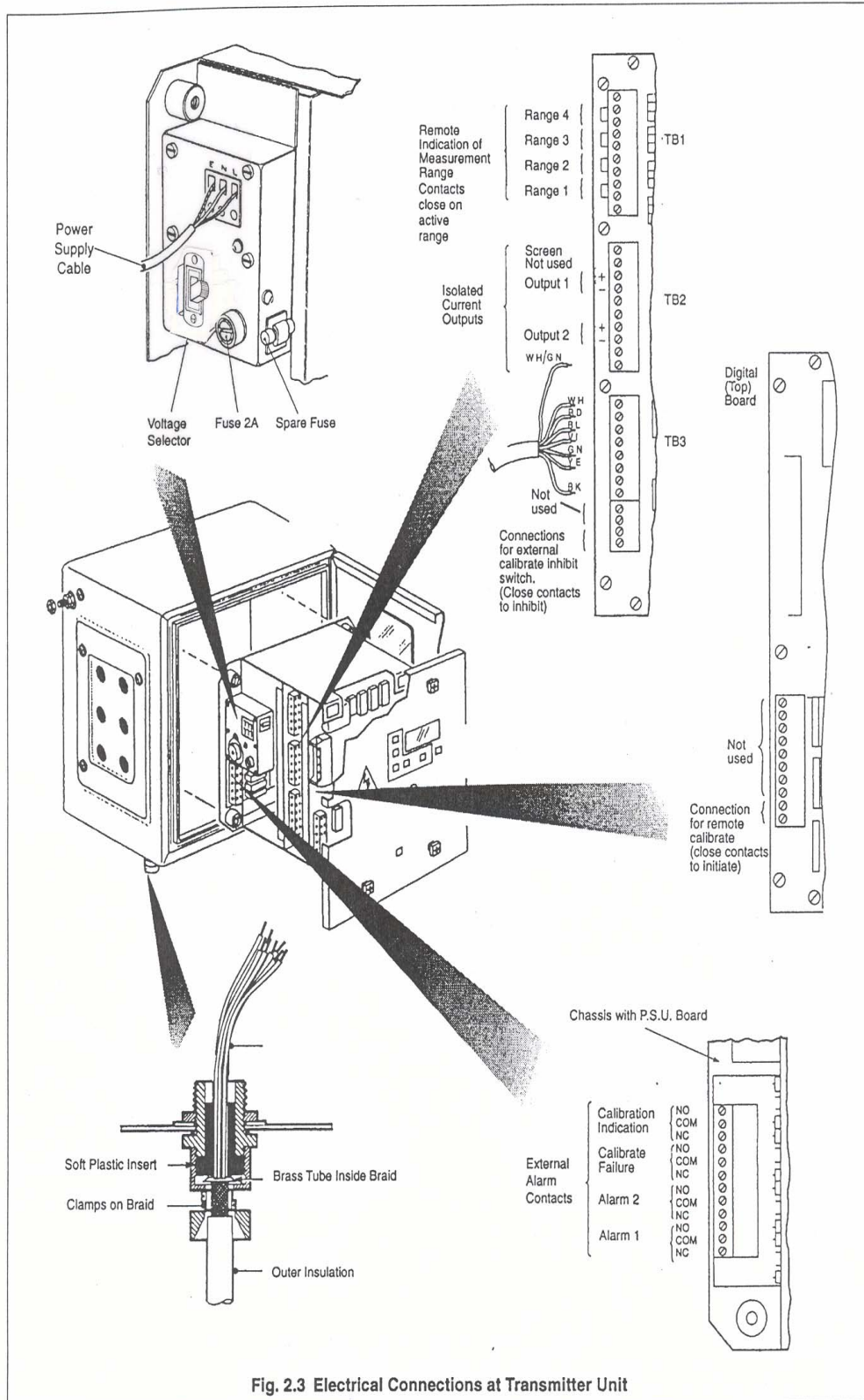
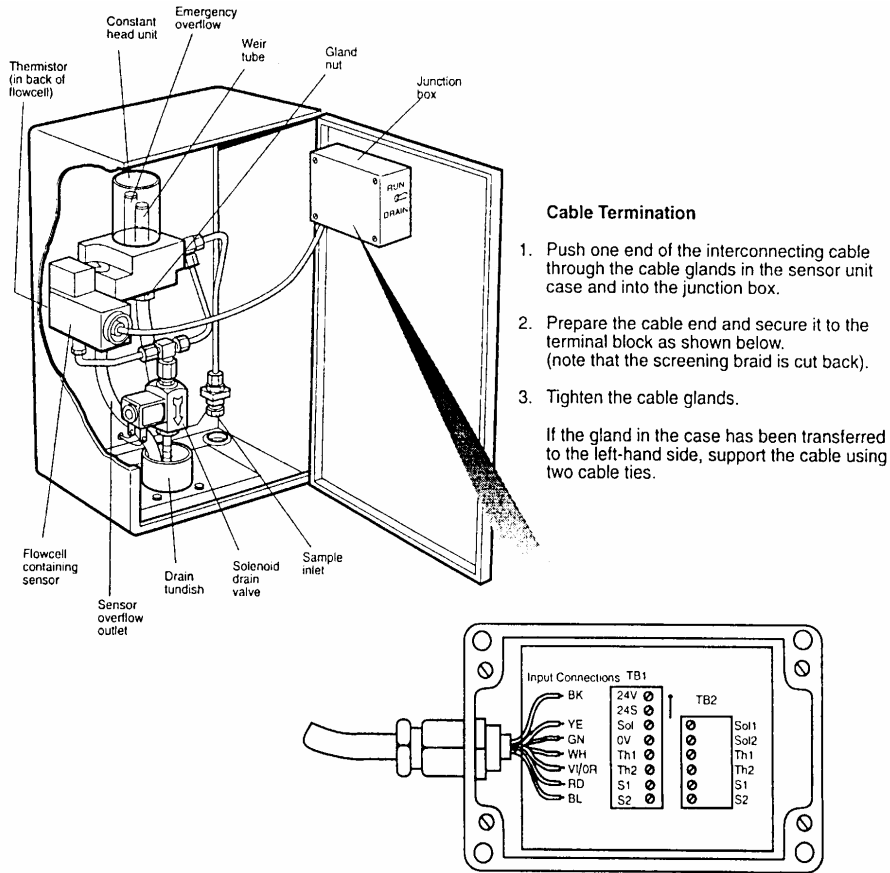

Fig. 2.3 Electrical Connections at Transmitter Unit

FIGURE 2.4 LOCATION OF ITEMS & CONNECTIONS IN THE SENSOR UNIT



2.4.2 TRANSMITTER UNIT

FIGURE 2.4 ELECTRICAL CONNECTS AT TRANSMITTER UNIT

To gain access to make the necessary connections, remove the chassis unit as described in Section 2.1.2.

- ✓ Allow enough cable from the sensor unit to reach inside the transmitter to terminate on terminal block TB3 on the analog (middle) board.
- ✓ Push the end of the cable through the liquid tight strain relief fitting in the side of the transmitter.
- ✓ Open the transmitter door, remove the front panel and pull the cable through the fitting.

- ✓ Noting that the screening braid terminates at Pin 10 of TB2 on the analog board. The terminal block may be pulled off the pins on the board if required.

⚠Caution. The terminal block for sensor unit connection has eight terminals, whereas there are 12 pins on the board. Make sure that the correct eight pins are chosen for connection; these are marked with a separate 'box' - see the following text and Figure. 2.4.

- ✓ Remove the access cover from the left-hand side of the transmitter case and fit suitable liquid tight fittings to take the cables necessary for the power supply, the output signals, the alarms and the remote functions, if used.
- ✓ Pass the cables through the fittings and noting that Pin 1 of each block is nearest the top of the case, prepare the ends of the cable and attach them to the terminal blocks as indicated in the following text - see also Figure. 2.4.

Digital Board (nearest front panel)

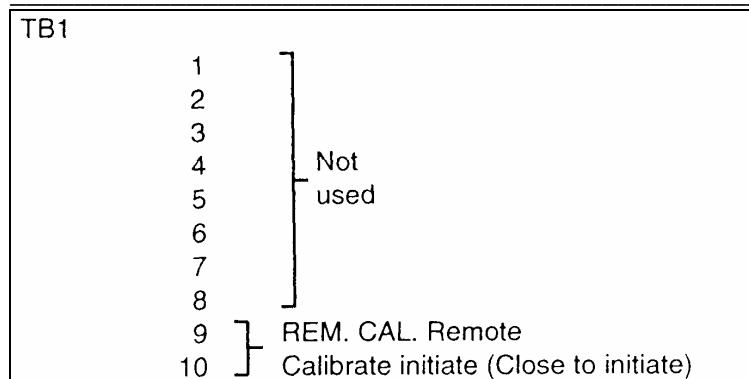

Analog Board TBI

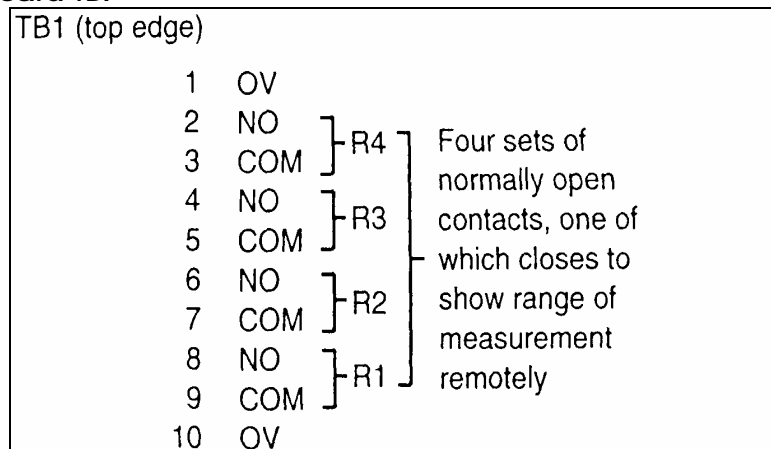

Analog Board TB2

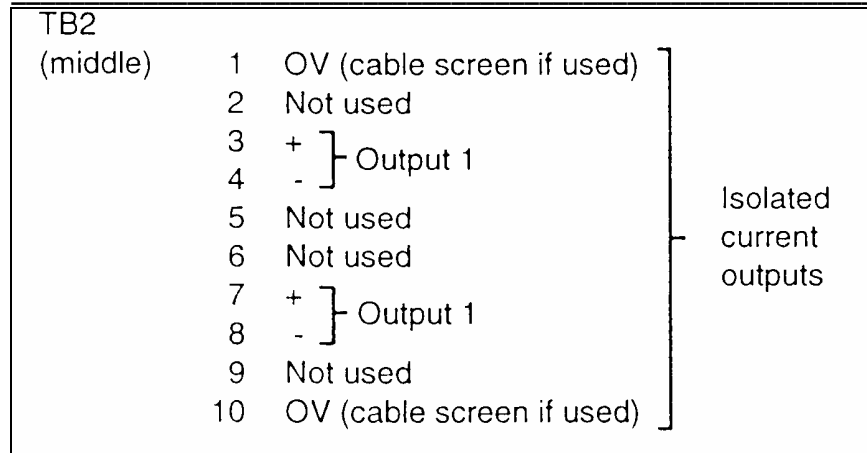

Analog Board TB3

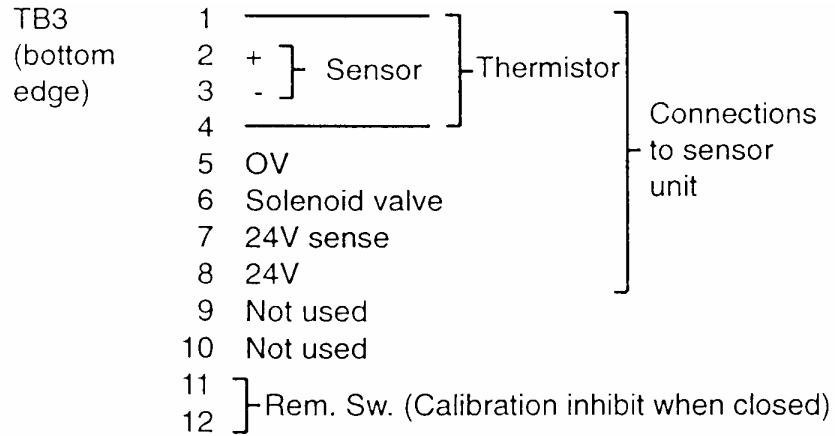

P.S.U. Board

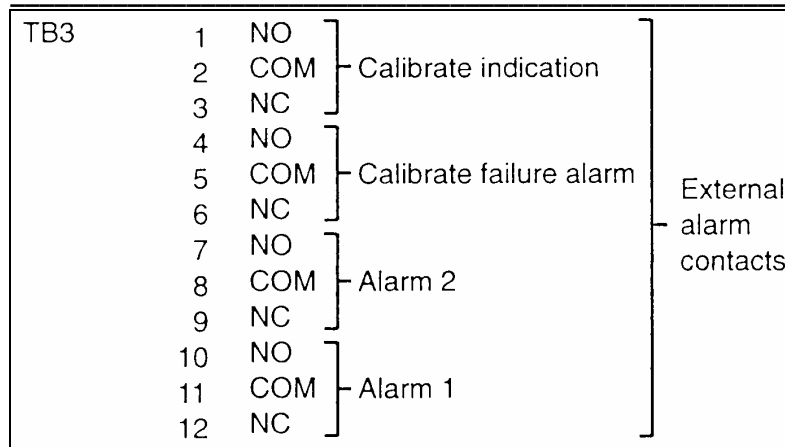

Chassis

A voltage selector is located next to the supply terminals and this must be set to the correct value before connecting the instrument to the supply - see Figure 2.4.

⊗Warning. The power supply ground (earth) must be connected to ensure safety to personnel, reduction of the effects of RFI interference and correct operation of the power supply interference filter.

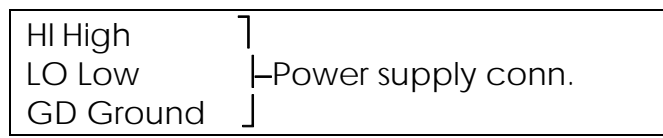

2.5 ANCILLARY EQUIPMENT

2.5.1 RECORDERS

The choice of two different isolated recorder output signals enables the instrument to be used with a wide variety of recording and data processing equipment. The load requirements are set out in Section 7, and the positions of the circuit board switches for the various outputs are given in Section 3.2.2.

2.5.2 RANGE INDICATION

The remote range indication relays connected at TB1 on the Analog Board can be used in several different arrangements to suit the

requirements of the installation. The relays can, for example, be wired directly into the PLC or data logger, but if a recorder is used, a method of indicating the set range will be required. A 2-pen recorder will be necessary, pen 1 indicating the oxygen concentration as above, and pen 2 recording the instrument range.

Suitable range indication recorder input can be provided using a resistor network. The network should be connected as shown in the two examples given in Fig. 2.4, and consists of four, $\frac{1}{4}$ watt resistors. A suitable resistor network kit is available as given in Section 6.

FIGURE 2.5 RESISTOR NETWORK FOR REMOTE RANGE INDICATION

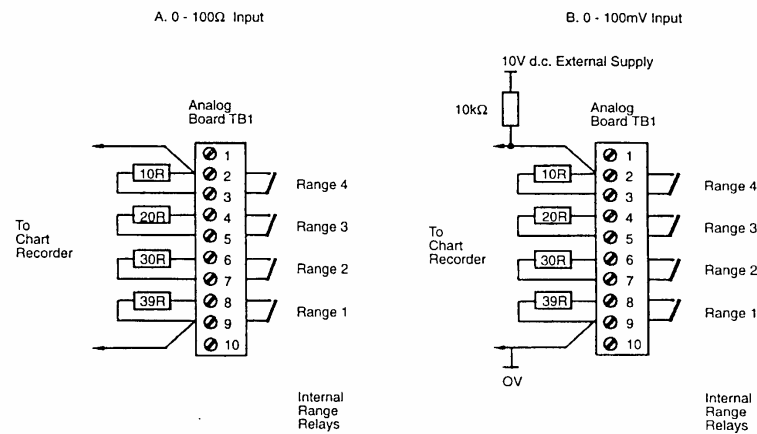

The recorder will give 60, 70, 80 and 90% scale deflection for ranges 1 to 4 respectively.

Other arrangements should be designed to suit the requirements of the system.

Make sure that all external equipment is set up and working according to the relevant instructions supplied with it.

3 START UP

- ✓ Open the case door and remove the front panel if this has not already been done.
- ✓ Set up the Transmitter as described in Section 4.2.2.
- ✓ Switch the battery switch SW10 to 'ON'.
- ✓ Replace the front panel and secure with the four plastic fasteners.
- ✓ Switch on the power at the external source and set the range switch to 'AUTO'. A calibration sequence will start immediately. This will cause a Calibration Fail Alarm (CF), which should be ignored at this stage.
- ✓ Open the door to the sensor unit and locate the relevant connector components attached to the junction box via their connecting cable.
- ✓ Remove the sensor capsule from its container, unscrew the sensor from the sealing plug and carefully plug the sensor onto the connector body ensuring that the sealing washer is in place - see Fig. 3.2. Retain the sealing plug and container for any shut down procedure required in the future. Hand tighten the connector nut onto the capsule.

⚠ Caution.

- ✓ Take special care to line up the two pins in the sensor capsule with their respective sockets before making the connection and tightening.
- ✓ Take care not to damage the delicate membrane on the end of the capsule.
- ✓ Make sure that the mating faces (carrying the electrical connection) of the sensor and connector body are clean and completely dry.

- ✓ Insert the sensor assembly into the flow cell, ensuring that the O'ring is in place, and tighten the clamping screw firmly.
- ✓ Make sure that the toggle switch on the junction box inside the door is at 'RUN'.
- ✓ Open the shut off valve upstream of the sensor unit and adjust until the sample is overflowing through the constant head vessel but is not fast enough to reach the emergency overflow.
- ✓ Close and lock the door.
- ✓ If an accurate figure for the atmospheric pressure at the sensor location is known, enter this value by pressing ATM at the same time as SET VALUE until the display reads the pressure value in mmHg.

- ✓ Carry out a manual calibration by pressing the CAL button on the front panel - see Section 4.2.1.
- ✓ Press the ALARM 1 button and the SET VALUE until the desired value of the lower alarm is shown on the digital display - see Section 4.2.4.
- ✓ Repeat for Alarm 2.
- ✓ After the calibration sequence has ended (see Section 4.1) the monitor will operate without further attention. A calibration sequence will be repeated every seven days if SW1.6 is 'OFF'.
- ✓ If desired, turn the range switch to one of the non-auto ranges.
- ✓ Close and lock the door of the transmitter unit.

Note. If the display flashes or shows anything other than the expected oxygen level, refer to Section 5.

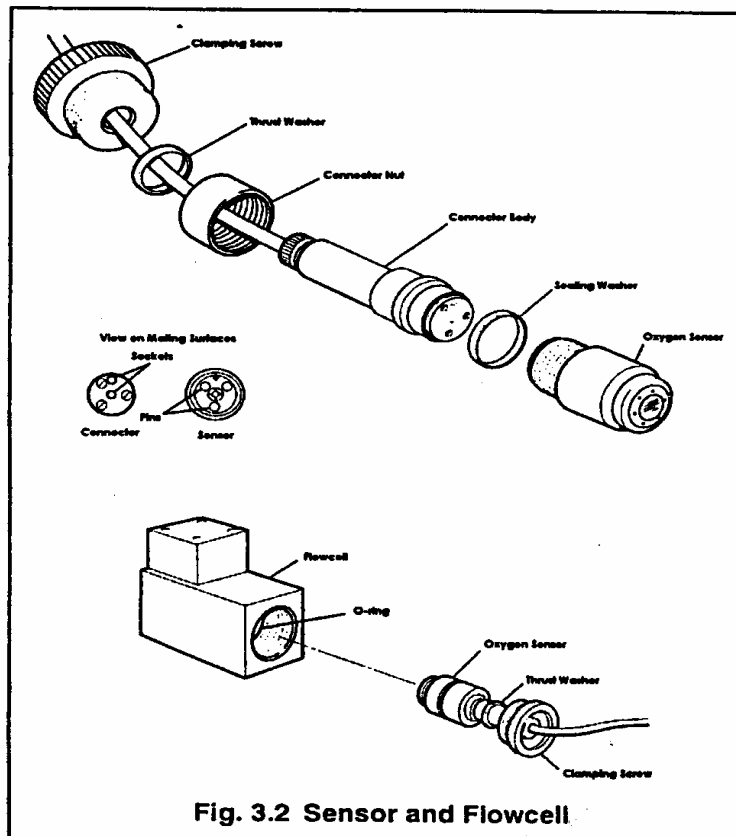

Fig. 3.2 Sensor and Flowcell

4 OPERATION

4.1 SENSOR UNIT

The model 9060 sensor unit is shown in Fig. 2.2. It consists of a metal case of similar construction to the transmitter case, with the pipework carrying the sample mounted on a panel bolted to the back with four M6 bolts.

Sample enters through a 1/4" compression fitting in the bottom of the case and travels to the sensor flow cell via two T-pieces. The other arm of the first T-piece is connected to a header tank which provides an adjustable constant head of sample. The second T-piece is connected to the solenoid valve which allows the flow cell to drain during the calibration sequence - see Section 5.1. Overflows from the constant head unit and the flow cell together with the drained sample from the solenoid valve fall to a drain cup in the bottom of the case. A schematic diagram of the sample flow is given in Figure 4.1

FIGURE 4.1 SCHEMATIC FLOW DIAGRAM

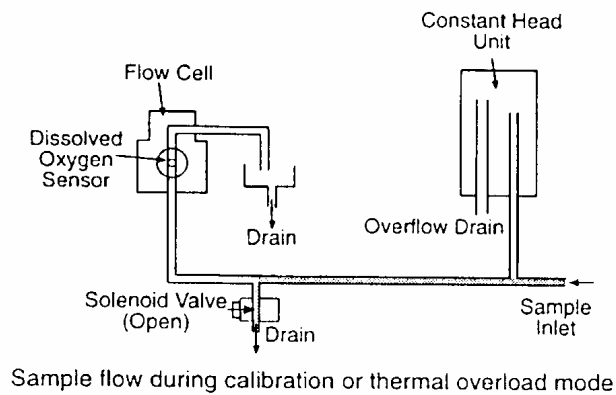
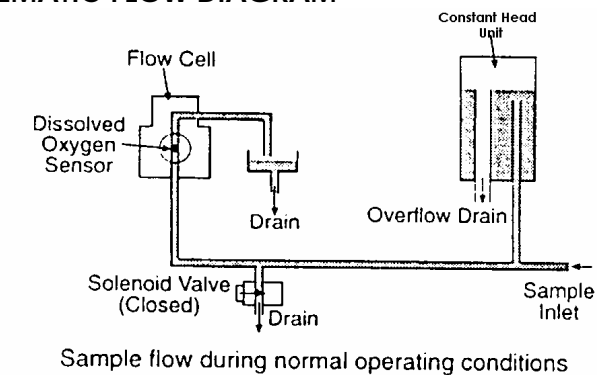

The oxygen sensor comprises a membrane-covered galvanic cell in the form of a disposable capsule with an expected life of at least six months of continuous operation; the galvanic cell utilizes a silver cathode and a lead anode to generate a current output proportional to oxygen partial pressure. The sensor capsule fits onto a plastic connector carrying the connecting cable and electrical contacts. The capsule assembly is clamped into the flow cell by a knurled clamping screw (see Figure. 3.2).

The flow cell also contains a thermistor for measurement of sample temperature and for automatic compensation of the variation in sensor output with temperature.

4.2 TRANSMITTER UNIT

4.2.1 ELECTRONIC CHASSIS

The chassis contains three circuit boards:

- ✓ **Digital Board** - nearest the front panel, contains the central processor unit, together with the controls and the display.
- ✓ **Analog Board** -middle, contains the analog input and current output circuits.
- ✓ **P.S.U. Board** -rear, the power supply and relay board.

Refer to Figure 4.3 for an indication of signal and power flows between these boards.

FIGURE 4.3 MONITOR SIGNAL AND POWER SYSTEMS-FLOW DIAGRAM

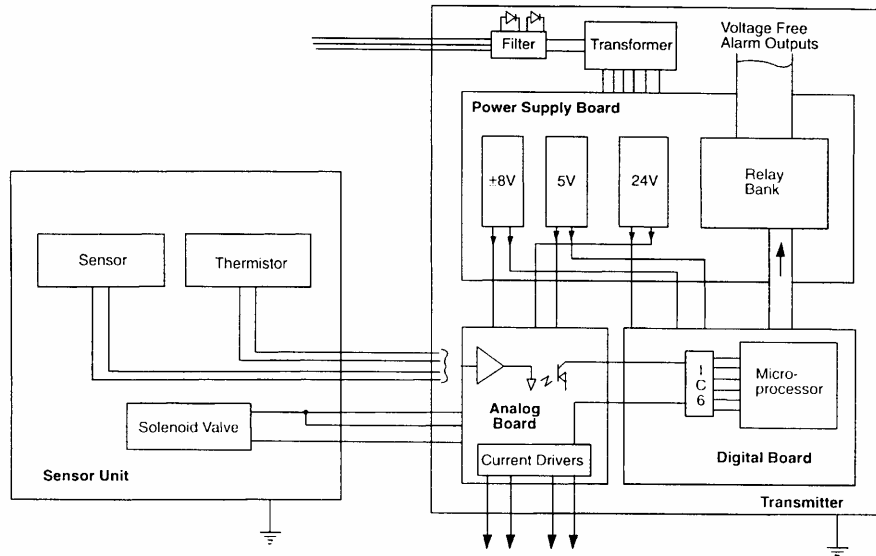

4.2.2 FRONT PANEL CONTROLS

The controls are mounted on the front circuit board of the chassis. They protrude through the holes in the front panel which is secured to the chassis by four plastic fasteners - see Figure. 4.4.

FIGURE 4.4 TRANSMITTER FRONT PANEL CONTROLS

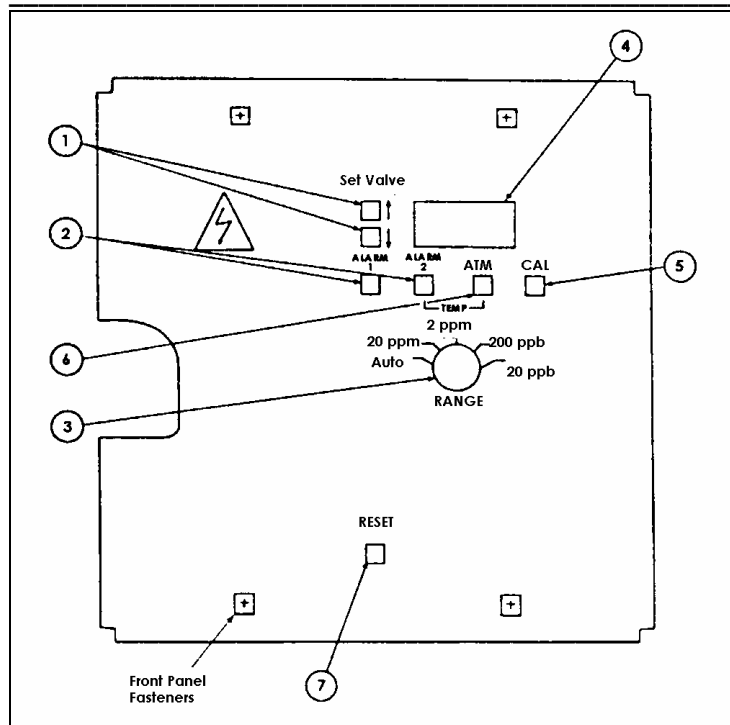

A 2½ red L.E.D. display shows the oxygen level in ppm (parts per million) or ppb (parts per billion).

The controls have the following functions:

1. **→RANGE switch:** 5 position: AUTO, 1, 2, 3 & 4. Positions 1, 2, 3 and 4 are the manual ranges corresponding to 0 to 20ppm, 0 to 2ppm, 0 to 200ppb and 0 to 20ppb respectively. At 'AUTO' the monitor automatically switches to a range suitable for the oxygen level being measured. Remote range indication is provided - see Section 2.5.2.
2. **°CAL:** When the button is pressed a calibration sequence occurs - see Section 5.1.
3. **←SET VALUE:** These buttons increase or decrease the value displayed on the digital indicator; used for setting the alarms and atmospheric pressure values.
4. **↑ALARM 1 & 2:** Used to set the values at which the alarm relays operate - see Section 4.2.4.
5. **±ATM:** This button allows the exact value of the local atmospheric pressure to be set into the monitor. With the ATM button depressed, the digital indicator display is adjusted to the desired value with the SET VALUE buttons see Section 4.2.5.
6. **"RESET:** Used to regain control of the instrument in the unlikely event of malfunction due to high power supply transients, etc. This button is not visible when the cabinet door is closed. The RESET button must be pressed after any switch position on SW1 is changed. See Section 4.2.3

4.2.3 PRINTED CIRCUIT BOARD

DIGITAL CIRCUIT BOARD

FIGURE 4.5 LOCATION OF ITEMS ON DIGITAL CIRCUIT BOARD

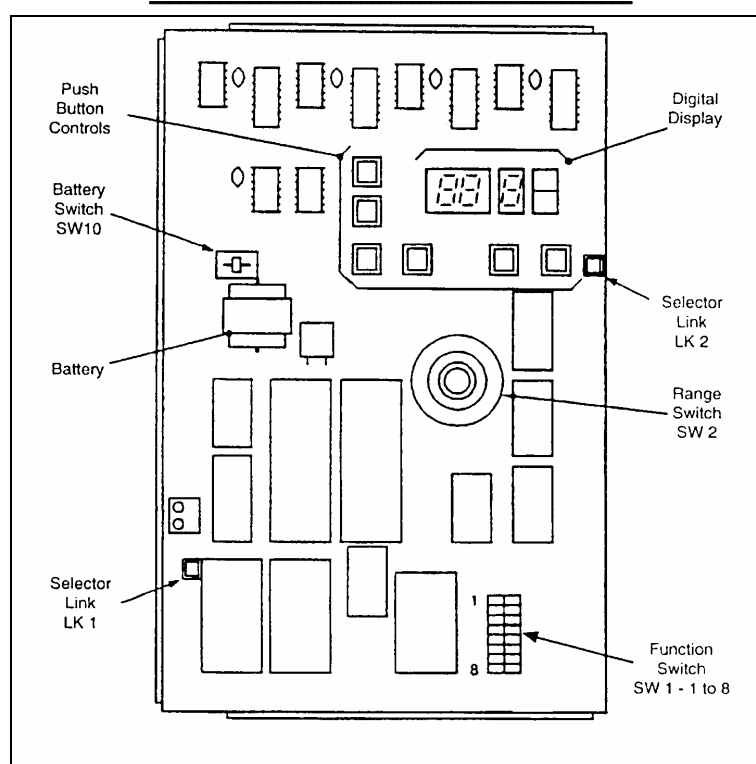

A series of eight on/off switches in a dual-in-line package is read by the microprocessor and provides controlling functions for the alarms, output current and auto calibration. The function of the switches are shown in Table 4.1.

TABLE 4.1 CIRCUIT BOARD FUNCTIONS

Switch SW1	Function	ON	OFF
.1	Set output current - See 'Analog Outputs'		
.2	Set output current - See 'Analog Outputs'		
.3	No Function		
.4	No Function		
.5	No Function		
.6	Calibrate	Manual Only	Auto/7 days
.7	Alarm 2	Normal	Fail-Safe - See 'Alarms'
.8	Alarm 1	Normal	Fail-Safe - See 'Alarms'

Note. SW1 switch positions are only read by the microprocessor when the unit is powered up or after pressing RESET. After changing any of the settings the RESET must be pressed.

Analog Circuit Board

Analog outputs

Two identical isolated current outputs are available at terminals 3(+), 4(-) and 7(+), 8(-) on the analog board. Both outputs may be set to one of the three current ranges by means of switches SW1.1 and SW1.2 on the digital board. In each case the upper current limit corresponds to the full-scale reading of the range displayed on the front panel. The switch settings are shown in Table 4.2.

TABLE 4.2 ANALOG OUTPUT CURRENT SELECTIONS ATR SW1 ON THE DIGITAL BOARD

Output Current	SW1.1	SW1.2
0 to 10mA	ON	ON
0 to 20mA	OFF	OFF
4 to 20mA	OFF	ON

Note. If SW1.1 is set to ON and SW1.2 to OFF, no valid output is produced.

4.2.4 ALARMS, DEAERATED WATER SYSTEM

Two oxygen level alarm controls relays are provided, each having one pair of changeover contacts rated at 2A, 250V a.c. (non-inductive). It is intended that both should operate as 'high' alarms, i.e. when the oxygen level increases beyond the set value. For example, the lower setting may act as a warning that the oxygen level has increased beyond a reasonable level, and the higher setting may be used in a shut-down capacity. The alarm values are set by pressing the relevant ALARM button in conjunction with the SET VALUE buttons.

The terminal connections are at TB3 on the PSU Board - see Section 2.4.2. In 'normal' operation the relay coil is energized causing the NO contacts to close when the displayed oxygen level is greater than the relevant alarm setting.

When set to 'fail-safe', by means of switches SW1.7 and SW1.8 of the function switch on the Digital Board, the relay coil is energized during normal non-alarm relay states and is de-energized upon recognition of an alarm condition. Thus if the power source fails, both external alarms are flagged indicating a malfunction.

Two other sets of relay contacts are provided. One set changes over during a calibration sequence and the other set changes over to indicate failure to calibrate.

4.2.5 ALARMS, OXYGENATED WATER TREATMENT SYSTEM

Two oxygen level alarm controls relays are provided, each having one pair of changeover contacts rated at 2A, 250V a.c. (non-inductive). It is intended that alarm 1 (A1) should operate as a 'low' alarm, i.e. when the oxygen level decreases below the set value, and alarm 2 (A2) should operate as a 'high' alarm, i.e. when the oxygen level increases above the set value. The alarm values are set by pressing the relevant ALARM button in conjunction with the SET VALUE buttons.

The terminal connections are at TB3 on the PSU Board - see Section 2.4.2. In 'normal' operation the relay coil is energized causing the NO

contacts to close when the displayed oxygen level is greater than the relevant alarm setting.

When set to 'fail-safe', by means of switches SW1.7 and SW1.8 of the function switch on the Digital Board, the relay coil is energized during normal non-alarm relay states and is de-energized upon recognition of an alarm condition. Thus if the power source fails, both external alarms are flagged indicating a malfunction.

Two other sets of relay contacts are provided. One set changes over during a calibration sequence and the other set changes over to indicate failure to calibrate.

4.2.6 ATMOSPHERIC PRESSURE COMPENSATION

The initial value is chosen when the instrument is commissioned to correspond to the normal atmospheric pressure at the geographical location of the site.

The approximate value as set by the switches may be improved upon by the use of the ATM push-button on the front panel, in conjunction with the SET VALUE buttons. The atmospheric pressure value is only used by the microprocessor during an autocalibration, which is carried out in air. Day-to-day variations in pressure due to changes in the weather do not affect the normal reading.

4.2.7 SAMPLE TEMPERATURE

The temperature of the sample water is continuously monitored by means of a thermistor housed in the sensor flow cell. If the temperature of the sample rises above 131°F (55°C), the display will read 'hot' and the solenoid valve will open to drain the flow cell. After 30 minutes the valve closes and the temperature is again measured. This procedure repeats until the sample temperature is less than 131°F (55°C), the monitor then returns to the 'RUN' mode.

If the sample temperature falls below 41°F (5°C) the dissolved oxygen concentration will still be displayed, but a fixed automatic temperature compensation appropriate to 41°F (5°C) will be applied.

5 CALIBRATION PROCEDURE

The monitor is programmed to operate with an automatic calibration sequence once every seven days. This period is timed from the sequence which occurs at power up or from a sequence initiated manually by pressing the CAL button, which can be done at any time. The autocalibration facility can be switched out, thus providing manual calibration only, by means of SW1.6 on the top digital board - see Section 4.2.2. During a calibration sequence the display on the front panel indicates 'CAL' and the CAL button illuminates. The full calibration sequence takes approximately 20 minutes and performs the following:

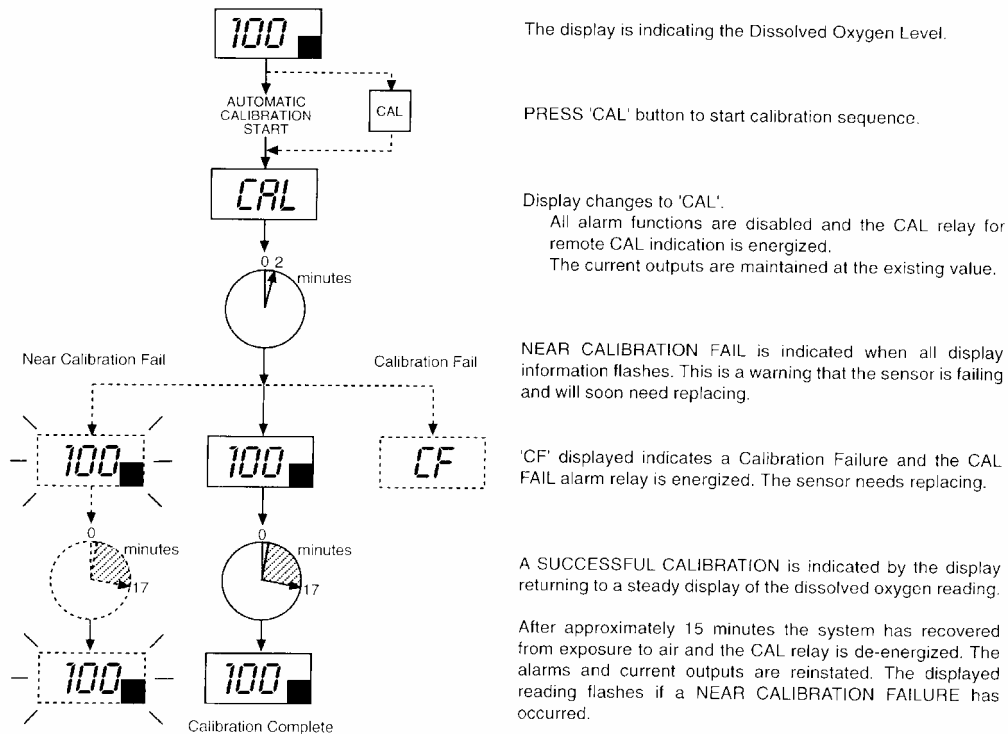

A calibration sequence may also be initiated remotely by momentarily closing a pair of contacts connected across the REM. CAL. input at terminals 9 and 10 of TB1 on the digital board - see Section 2.4.2. This action performs exactly the same function as pressing the CAL button on the front panel.

An additional facility is provided whereby the calibration sequence can be inhibited remotely. A contact closure across terminals 11 and 12 of TB3 on the analog board (see Section 2.4.2) will cause any calibration sequence in progress to be lost and will prevent an imminent sequence from starting. This facility can be used with an external flow detector to inhibit a calibration sequence upon loss of sample, thereby preventing prolonged exposure to air of the sensor.

6 MAINTANENCE

6.1 SCHEDULED SERVICING

No routine maintenance is required for this instrument other than periodically pressing the CAL button to initiate a calibration sequence if manual calibration has been chosen.

6.2 UNSCHEDULED SERVICING

The monitor will indicate that abnormal operation is taking place by means of signals on the digital display. These are listed in Table 6.1.

TABLE 6.1 FAULT FINDING INDICATIONS ON THE DISPLAY

Table 6.1 Fault Finding Indications on the Display

FAULT	POSSIBLE CAUSE
Display reads 'CAL'	Normal reading when calibration is taking place – no action required
Display flashes continuously	Near Calibration Fail – Sensor nearing end of life, replace capsule soon, see Section 6.2.1
Display reads 'CF'	Calibration Fail – Sensor giving insufficient output. Replace sensor capsule immediately – see Section 6.2.1
Display reads 'hot'	Sample temperature has risen above 131 deg. F (55 deg. C), check cause. See Section 4.2.6

6.2.1 REPLACEMENT OF THE SENSOR

- ✓ Open the door to the sensor unit and switch the toggle switch on the junction box inside the door to 'DRAIN'. Leave the switch in this position.
- ✓ When the flow cell has drained, unscrew the clamping screw and remove the sensor assembly from the front of the flow cell. Unscrew the connector nut, remove the old sensor capsule and discard both capsule and sealing washer.
- ✓ Inspect the sensor. If the membrane is clean, replace the sensor - proceed to next step. If deposits are visible on the membrane, remove them by gently wiping the membrane with a moist paper tissue; for oily or greasy deposits, the tissue may be moistened with a mild detergent or, if necessary, with isopropyl alcohol. After cleaning, dry the interior of the flowcell with a paper tissue or soft cloth, make sure that the O'ring is correctly positioned

against the shoulder near the end of the cavity - proceed to fourth step below to test the sensor.

- ✓ Unscrew the connector nut, remove the old sensor capsule and discard both capsule and sealing washer.

 **Caution.**

- ✓ Take special care to line up the two pins in the sensor capsule with their respective sockets before making the connection and tightening.
- ✓ Take care not to damage the delicate membrane on the end of the capsule.
- ✓ Make sure that the mating faces (carrying the electrical connection) of the sensor and connector body are clean and completely dry.

- ✓ Take out the O'ring from the flow cell, dry the interior of the flow cell with a tissue or soft cloth and insert the new O'ring, making sure it is correctly located on the shoulder near the end of the cavity.
- ✓ Remove the new sensor capsule from its container, unscrew the sensor from the sealing plug and carefully plug the sensor onto the connector body making sure that the new sealing washer is in place - see Fig. 3.2. Retain the sealing plug for any shut down procedure required in the future. Hand tighten the connector nut onto the capsule.
- ✓ Carefully insert the sensor/holder assembly into the flow cell and tighten the retaining nut firmly.
- ✓ Return the toggle switch to the 'RUN' position.
- ✓ Close and lock the sensor unit door.
- ✓ Press the CAL button on the transmitter unit to start a calibration sequence.

Note. The RUN/DRAIN switch is provided to facilitate installation and removal of sensors and should only be used for that purpose. Avoid unnecessary exposure of the sensor to air. In addition, the configuration of the system is such that the reading displayed when switched to 'DRAIN' does not represent the dissolved oxygen content of air-saturated water at the prevailing ambient temperature.

6.3 SHUT DOWN PROCEDURE

6.3.1 SENSOR UNIT

- ✓ Close the valve upstream of the monitor.
- ✓ Set the toggle switch on the junction box inside the door to 'DRAIN'; when the flow cell is empty, return the switch to the 'RUN' position.
- ✓ Unscrew the clamping screw and remove the sensor assembly from the flow cell.
- ✓ Loosen the connector nut, pull the sensor off the connector body and screw the sensor into the sealing plug which was retained during installation.
- ✓ Store the capsule in its provided canister so that the membrane is in contact with the sponge pad. Make sure that the pad is wet.
- ✓ Dry the connector assembly and the interior of the flow cell with a tissue or soft cloth.
- ✓ Fit the connector assembly into the clip provided and close the door. Take care not to lose the capsule sealing washer.

 **Caution.** The connector body should not be replaced in the flow cell without a capsule attached.

6.3.2 TRANSMITTER UNIT

Isolate the electrical supply to the unit. In the case of power loss, the programmed data will be retained for up to 10 years.

6.4 SIMPLE ELECTRONIC CHECK

If a problem with the monitor occurs, a current (μA) source and a resistance box may be used to test the transmitter.

A Waltron L.L.C. model 9439-950 Sensor Simulator is available to make an overall check on the functioning of the transmitter unit.

The simulator, which connects to the analog board, produces a μA output to simulate the oxygen sensor signal and also provides the necessary resistance to simulate thermistor values. Consult the simulator manual for full details of its use, or connect a μA source plus a resistance box to the transmitter.

Note. The monitor calibration signals are established by read-only software and cannot be changed by users. A simulated calibration must therefore be carried out as indicated below.

6.5 MAINTANENCE

Proceed as follows:

- ✓ Open the sensor unit door and locate the junction box mounted on the door - see Fig. 2.2.
- ✓ Open the junction box and disconnect the sensor and thermistor wires as follows:

+ve sensor (RD) from: S1
 -ve sensor (BL) from: S2
 Thermistor 1 (WH) from: Th1
 Thermistor 2 (OR) from: Th2

- ✓ Connect the appropriate wires of the current source and resistance box to TB2 as follows:

μ A source +ve to: S1
 μ A source -ve to: S2
 Resistance Box to: Th1
 Resistance Box to: Th2

- ✓ Set the appropriate resistance value corresponding to the thermistor resistance at the nominal sample temperature, e.g. 20°C = 12.5 k Ω
- ✓ Set the atmospheric pressure compensation to 760.
- ✓ Set the current source to 25 μ A.
- ✓ Initiate a calibration sequence by pressing the CAL button.
- ✓ After three minutes the display should read the appropriate concentration value (see below).
- ✓ With different μ A values, the monitor range can be checked. The relevant values are as follows:

6.6 Current Input (μ A) Display Reading

25.00	9.6ppm
15.00	5.7ppm
6.00	2.3ppm
0.40	155.0ppb
0.018	6.9ppb

Note. When the electronic systems are operating correctly, the displayed concentration value should be within 5% of the selected value.

Sensor Electrical Check:

A simple electrical check can be performed to check status of sensor. Current output (micro amp) of dissolved oxygen probe must be greater then 15 μA . To test current output of sensor, connect current meter to terminal leads on dissolved oxygen probe. Measure current output in μA , replace sensor if output is less then 15 μA .

7 SPARE PARTS

7.1 Recommended Spare Parts

Part Number	Description
K3010-161	Sensor Replacement Kit

7.2 Sensor Unit

K3500-356	Retubing Kit
K1148-020	Stainless Steel Solenoid Valve (Order only if replacing stainless steel solenoid valve)
K3500-359	Stainless Steel Solenoid Valve Upgrade Kit (Order only if replacing clear acrylic solenoid valve)
K3010-164	Thermistor Assembly
K1048-600	O'Ring for Thermistor
K1048-604	Sealing Washer O2 Sensor
K1152-200	Nupro Filter, Stainless Steel, 60 Micron
K1048-612	O'Ring, O2 Sensor

7.3 Transmitter Unit

K1092-025	Fuse, 2A Ceramic
K2014-419B	Digital Circuit Board with contacts & display
K2014-401C	Analog Circuit Board
K2014-402B	Power Supply Circuit Board
K3500-200	Desiccator Strip
K3500-201	Resistor Kit - Remote Range
K3500-202	Resistor Precision 49.9 ohms, 20mA/1VDC
K3500-203	Resistor Precision 249 ohms, 0mA/5VDC
K3500-204	Resistor Precision 499 ohms, 20mA/10VDC
K1086-160	8-Way Cable (Specify Length) Hi-Level Measurement (EPROM) upgrade for
K1091-008	Oxygenated Water Treatment
K3400-008	Sentry 8-Point Sampling Sequencer
K1148-004	4-Point Manifolder Sampling Valve
K1148-008	8-Point Manifolder Sampling Valve
K1138-633	8-Pt Sample Inlet Connections (1/8" OD Swagelok)
K1138-634	8-Point Sample Outlet Connections (1/8" x 1/8")
K3500-357	Kit, Sentry Sampling Sequencer - 8 Point
K3500-358	Kit, Sentry Sampling Sequencer - 4 Point
K2004-255	Power Cord Assembly (6 ft.)
K1058-180	Latch (with key)
K2004-242A	Interconnect Cable Ass'y (6')
K7500-001A	Test Strip, 9060

8 SPECIFICATION

- Range:** 0 to 19.9ppb, 0 to 199ppb
0 to 1.99ppm, 0 to 19.9ppm
- Accuracy:** $\pm 5\%$ of reading or ± 1 ppb, whichever is greater.
- Response Time:** 90% of a step change in 1 minute.
- Stability:** $\pm 5\%$ or reading or ± 1 ppb per week, whichever is the greater.
- Outputs:** Two isolated current outputs in the range 0 to 10, 0 to 20 or 4 to 20mA. Maximum impedance 1k Ω .

8.1 Remote Range

- Indication:** Four voltage free contacts rated at 250V, 2 amp non-inductive.
- External Alarms:** Two concentration alarms.
Normal or Fail Safe.
Calibration Mode Indicator.
Calibration Fail Indicator.
All voltage free contacts rated at 250V, 2 amp non-inductive.
- Inputs:** Remote initiation of calibration sequence.
- Calibration:** Automatic air calibration every 7 days or manually initiated when required.

8.2 Installation Information

- Sample Temp.:** 41°F to 131°F (5°C to 55°C).
- Sample Flow:** 100 to 500 ml/min.
- Sample Pressure:** Maximum 15 bar (217.5 psi).
- Ambient Temp.:** 32°F to 131°F (0°C to 55°C).

Dimensions of

- Sensor Unit:** 300mm wide x 400mm high x 200mm deep.

Mounting for

- Sensor Unit:** Four holes 8.5mm diameter, spaced 230mm horizontal, 330mm vertical.

Weight of**Sensor Unit:** 22lb. (10kg).**Connections to****Sensor Unit:** Sample Inlet ¼" (6mm) o.d. compression fitting.
Sample Outlet 3/8" (10mm) flexible tubing.
Atmospheric Drain.
Sample Line Material - Stainless Steel.
Electrical: via liquid tight fitting, cable size 7 to 10.5mm.**Max. Core Size:** Main Power - 32/0.2mm
Signal - 24/0.2mm**Dimensions of****Transmitter Unit:** Four holes 8.5mm diameter, 230mm horizontal, 230mm vertical.**Weight of****Transmitter Unit:** 24lb. (11kg).**Electrical Conn.:** via liquid tight fitting as required.**8.3 Power Supply****Requirements:** Volts 100/110/120/200/220/240; 50/60 Hz; 199VA.**8.4 Power Supply****Tolerances:** Voltage +10%, -20%.
Frequency min. 47Hz, max. 65Hz.**8.5 Case Protection****of Transmitter:** IP55**Maximum Distance
Between Sensor and****Transmitter Unit:** 325 feet (100 meters).

9 OPERATOR'S NOTE

10 OUR COMMITMENT TO OUR CUSTOMERS

The instruction manual that you have received is a technical guide to aid you in the set-up and maintenance of your new Waltron measuring system.

Any technical product questions you may have after reading this tool should be addressed to our Technical Service Specialist:

Waltron L.L.C.
(800) 242-7353
www.waltronltd.com

Waltron's technical expertise and extensive experience has enabled us to provide personalized solutions to the water quality industry. It is Waltron's commitment to provide you with timely and accurate technical service and support.

We know that you will be satisfied with the quality, performance and cost of ownership of our product. If you are not, please contact me directly in Whitehouse, NJ at (800) 242-7353. I will address your concerns personally and promptly. Thank you for choosing Waltron L.L.C. as your Water Chemistry Managers.

email: info@waltronltd.com

11 OBSERVING SAFETY

Please observe proper safety and handling precautions when installing, operating, maintaining and servicing this product. The following should be noted and adhered to:

- ✓ This instruction manual should be carefully read before proceeding.
- ✓ Warning labels on enclosures, containers, packages and chemicals must be abided by.
- ✓ Only qualified personnel that have been trained in accordance to the information provided should be involved in the installation, operation, and servicing of the analyzer.
- ✓ To avoid accidents from occurring, normal safety precautions must be followed when operating the analyzers in conditions of high pressure and/ or temperature.
- ✓ The chemicals that are used to operate this machine must be stored away from heat, protected from temperature extremes and powders kept dry.
- ✓ Follow all regulations and warning labels when disposing of chemicals. Do not mix the chemicals together.

To obtain safety advice concerning the use of the analyzer and reagents in this manual or any relevant Material Safety Data Sheets (MSDS) please contact Waltron L.L.C. Please note that Waltron L.L.C. mailing and UPS shipping addresses differ.

DIRECT ALL CORRESPONDENCE TO:

**Waltron L.L.C.
P.O. Box 70, 50 Tannery Rd.
Whitehouse, NJ 08888**

**Phone: (800) 242-7353
Fax: (908) 534-5546
Web Site: www.waltronltd.com**

DIRECT ALL UPS SHIPMENTS TO:

**Waltron L.L.C.
50 Tannery Rd.
Somerville, NJ 08876**

12 WARRANTY AGREEMENT

If you experience any defects in materials or find fault in manufacture of the goods that you have received within one year from the date of shipment, Waltron L.L.C. will repair, or at its option, replace the defective part free of charge. This is providing that the part is returned to Waltron L.L.C. in Whitehouse, NJ. Shipping charges must be prepaid. At Waltron L.L.C.'s discretion, a Technical Service Specialist will repair/ replace the defective parts on location. It is at the customers expense to pay for traveling time and expenses of the Technical Service Specialist.

Instruments sent to Waltron L.L.C. must be appropriately packed and the following information must be provided prior to returning to Waltron L.L.C.:

- ✓ Waltron L.L.C. will assign a Return Authorization Number to you.
- ✓ The name and address of the company returning the items for repair.
- ✓ The department within the company returning the items for repair.
- ✓ The name, telephone number and extension of the individual in the company responsible for returning items for repair.
- ✓ A brief description of the fault.
- ✓ Ship to the Waltron L.L.C. Service Center

VIA MAIL
Waltron L.L.C.
P.O. Box 70, 50 Tannery Rd.
Whitehouse, NJ 08888

Waltron L.L.C. Warranty Agreement:

- ✓ Covers expendable sensors for one month after shipment and reusable electrodes for six months after shipment.
- ✓ Does not apply to damage sustained in transit
- ✓ Shall cease to have effect if the goods have been used for purposes other than those for which they are intended or not in accordance with Waltron L.L.C. instructions, or if any seal has been removed, broken or tampered with or if the Waltron L.L.C. trademark or serial number has been removed, defaced or altered.

- ✓ Does not cover expendable supply items such as reagents, tubing and electrolytes.
- ✓ Does not cover misuse or mistreatment by the user.
- ✓ Does not cover previous repair or alteration by unauthorized repairmen and/ or repair facility.

Waltron L.L.C. does not assume responsibility for contingent liability through alleged failure or failures of any of its products or their accessories.

International

All international orders will have a warranty period of one year after installation or 18 months after shipping date, whichever occurs first. All other domestic criteria applies.

13 CHECK-LIST OF MATERIALS

Waltron L.L.C. concern does not stop when your instrument leaves our loading dock. We want to thank you for your confidence in Waltron L.L.C., our product and the service that we provide. We want to make sure that your experience with us will be one of total satisfaction starting with the condition in which you have received your product.

- ✓ Inspect all shipping containers upon receipt and record any visible damage. Count the number of packages, making sure that the number is in agreement with the shipping paperwork. If there are any outward signs of damage, please retain all containers and packages for inspection by carrier. It is generally good practice to retain the packing material and boxes as they make an excellent way to protect the instrument if you move it or ever need to ship the instrument.
- ✓ Make sure that all items received match the packing list. If you ordered chemicals, they are usually shipped in a separate package and will be itemized accordingly.
- ✓ Verify that the number of packages received agrees with the package list and shipping papers.
- ✓ Notify both Waltron L.L.C. and the carrier, if any problems occur.