



EXPERTS IN WATER CHEMISTRY SINCE 1903



## **9065C Portable Luminescent Dissolved Oxygen Analyzer Instruction Manual**

Revision 2.04



---

## WALTRON CUSTOMER COMMITMENT

This instruction manual is a technical guide to aid the customer in the set-up, operation, and maintenance of their new Waltron measuring system. Waltron provides continuous product improvement and reserves the right to make any modifications to the information contained herein without notice.

*Copyright © Waltron Bull & Roberts, LLC, 2016  
All Rights Reserved*

Technical questions concerning this product should be addressed to:

**Waltron Technical Service Department**  
Flemington, New Jersey  
**Phone:** (908)-534-5100  
**Fax:** (908)-534-5546  
[www.waltron.net](http://www.waltron.net)

Please be ready to provide the following information:

- Date analyzer was purchased
- Analyzer model and serial number
- Recent maintenance history
- Calibration slope values and detailed description of problem

Waltron's technical expertise and extensive experience provides personalized solutions to the water quality industry. It is Waltron's commitment to provide the customer with timely and accurate technical service and support.

Waltron fully expects the customer to be satisfied with the quality, performance, and cost of this product.

If there are any questions or concerns regarding this product, please feel free to contact Waltron at (908)-534-5100.

**Thank you for choosing Waltron!**

Please note the Waltron mailing and shipping address:

Waltron Bull & Roberts, LLC  
25 Minneakoning Road, Suite 101  
Flemington, NJ 08822

---

## SAFETY

Please observe proper safety and handling precautions when installing, operating, maintaining, and servicing this product. The following should be noted and adhered to:

- Read and understand manual before working with analyzer.
- Pay special attention to warning labels on enclosures, containers, packages and chemicals.
- Only qualified personnel should be involved in the installation, operation, and servicing of the analyzer.
- Follow safety precautions when operating analyzer in conditions of high pressure and/or temperature.
- Keep analyzer chemicals away from heat and extreme temperatures. Reagent powders must be kept dry.
- Follow all regulations and warning labels when disposing of chemicals. Do not mix chemicals.

To obtain analyzer safety information or Safety Data Sheets (SDS), please contact Waltron or visit the website at [www.waltron.net](http://www.waltron.net) .



---

## WARRANTY AGREEMENT

If, within one year from the date of shipment, the customer experiences any equipment defects or is not satisfied with the analyzer manufacturing, Waltron will repair, or at its option, replace any defective part(s) free of charge. This warranty requires that the defective part(s) be returned to Waltron with shipping charges prepaid.

At Waltron discretion, a Technical Service Specialist may be sent out to repair or replace the defective part(s) on location. Traveling time and expenses of the Technical Service Specialist is at the customer's expense.

Equipment sent to Waltron must be appropriately packaged and the following information must be provided prior to returning to Waltron:

- The Return Authorization (RA) number assigned to the customer by the Waltron Technical Service Department
- Customer name, address and department
- Name and telephone number of the individual responsible for returning items for repair
- Brief problem description

### **Ship to Waltron service center:**

Waltron Bull & Roberts, LLC  
25 Minneakoning Road, Suite 101  
Flemington, NJ 08822

### **The Waltron Warranty Agreement:**

- Covers expendable sensors for one month after shipment and reusable electrodes for six months after shipment.
- Does not apply to damages occurred during shipping.
- Warranty will be nullified if goods have been used for purposes other than those for which they are intended or if any seal has been removed, broken or tampered with or if the Waltron trademark or serial number has been removed, defaced, or altered.
- Does not cover expendable supply items such as reagents, tubing and electrolytes.
- Does not cover misuse or mistreatment by the user.
- Does not cover previous repair or alteration by unauthorized individuals.

Waltron does not assume responsibility for contingent liability through alleged failure or failures of products or product accessories.



## CHECKLIST OF MATERIALS

- In order to ensure customer satisfaction, Waltron does its best to provide adequate and timely packaging and shipping services. Please perform the following after receiving a shipment:
- Inspect all shipping containers upon receipt and record any visible damage. If there are any outward signs of damage, please retain all containers and packages for inspection by carrier. Please retain all packing material so that it can be used for future moving and shipping needs.
- Check all items received against those on the packing list. Chemicals are usually shipped in a separate package and will be itemized accordingly.
- Verify that the number of packages received agrees with the packing list and shipping papers.
- Notify both Waltron and the carrier if any problems occur.

### **Important Notice:**

- All analyzers are inspected and tested prior to shipment.
- In normal use, the unit should require only minor maintenance and should operate correctly and without fault over a long period of time.
- Please note that if electronic components need to be replaced, it may be necessary to adjust and/or calibrate the analyzer.
- Failure to carry out correct maintenance procedures may result in inaccurate analyzer readings.



## TABLE OF CONTENTS

<b>Waltron Customer Commitment .....</b>	<b>1</b>
<b>Safety.....</b>	<b>1</b>
<b>Warranty Agreement.....</b>	<b>3</b>
<b>Checklist of Materials .....</b>	<b>3</b>
<b>Table of Contents .....</b>	<b>5</b>
<b>List of Figures .....</b>	<b>7</b>
<b>List of Tables.....</b>	<b>8</b>
<b>1 Overview .....</b>	<b>9</b>
1.1 Technical Specifications.....	9
1.2 Intended Use .....	10
1.3 Safety .....	11
1.3.1 Symbols.....	11
1.3.2 Precautionary Measures and Safety Instructions .....	11
<b>2 Introduction .....</b>	<b>12</b>
2.1 Analyzer Overview .....	12
2.2 O <sub>2</sub> Measurement Principle .....	13
<b>3 Installation .....</b>	<b>15</b>
3.1 Content of the Delivery .....	15
3.2 Pre-Installation.....	15
3.3 Installation .....	16
3.4 Units .....	16
3.5 Time Settings.....	17
3.5.1 Date.....	17
3.5.2 Time .....	17
3.5.3 Shut-off Time .....	17
3.5.4 Display Contrast .....	17
3.5.5 Display Times .....	18
3.6 Product Definition .....	18
3.6.1 Product.....	18
3.6.2 O <sub>2</sub> Sampling Time.....	18
3.7 Language.....	19
3.8 ID System/Password.....	19
3.8.1 Password.....	19
<b>4 Operation .....</b>	<b>20</b>
4.1 General Information .....	20
4.2 Operation Procedure.....	20
4.3 Measurement Choice.....	22
4.3.1 O <sub>2</sub> Measurement.....	23
4.3.2 O <sub>2</sub> Continuous Measurement .....	23



---

4.4	Reading the Measurement Results .....	24
4.5	Deleting Measurement Results .....	24
4.6	Product Choice .....	24
4.7	Charging the Battery .....	25
<b>5</b>	<b>Calibration and Compensation .....</b>	<b>27</b>
5.1	Calibration of the Temperature Sensor .....	27
5.2	Calibrating the O <sub>2</sub> Sensor .....	27
5.2.1	Calibration Frequency .....	27
5.2.2	One point Calibration .....	28
5.2.3	Calibration with Two Gases .....	28
<b>6</b>	<b>Cleaning and Maintenance .....</b>	<b>32</b>
6.1	Daily Cleaning.....	32
6.2	Monthly Maintenance.....	32
6.2.1	Special Cleaning.....	32
6.2.2	Throttle Valve Chamber .....	33
<b>7</b>	<b>Troubleshooting and Repair.....</b>	<b>34</b>
7.1	Troubleshooting List.....	34
7.2	Replacing the Battery Pack.....	35
7.3	Replacing the O <sub>2</sub> Sensor.....	35
<b>8</b>	<b>Deactivating, Storage and Transport.....</b>	<b>37</b>
8.1	Deactivating.....	37
8.2	Storage.....	37
8.3	Transport .....	37
<b>9</b>	<b>Spare Parts .....</b>	<b>38</b>
<b>Appendix A: Formulas.....</b>		<b>40</b>
<b>Appendix B: Software Structure .....</b>		<b>41</b>



---

## LIST OF FIGURES

<b>Figure 2.1: Analyzer overview.....</b>	<b>12</b>
<b>Figure 2.2: Control buttons. ....</b>	<b>13</b>
<b>Figure 2.3: Luminescence in the absence of oxygen (1) and in the presence of oxygen (2). ....</b>	<b>14</b>
<b>Figure 2.4: Optical sensor depiction .....</b>	<b>14</b>
<b>Figure 3.1: O-Ring installation .....</b>	<b>16</b>
<b>Figure 4.1: Flow profile.....</b>	<b>21</b>
<b>Figure 4.2: 9065C display during a measurement.....</b>	<b>22</b>
<b>Figure 4.3: 9065C display during a measurement.....</b>	<b>22</b>
<b>Figure 4.4: Oxygen content display.....</b>	<b>23</b>
<b>Figure 4.5: Display during a temperature measurement. ....</b>	<b>23</b>
<b>Figure 7.1: Measurement chamber unit.....</b>	<b>36</b>





## LIST OF TABLES

<b>Table 4.1: Charge cycle and LED indications on the quick-charger.....</b>	<b>26</b>
<b>Table 8.1: Main component materials.....</b>	<b>37</b>
<b>Table 9.1: Spare Parts Listing. ....</b>	<b>38</b>

# 1 OVERVIEW

## 1.1 TECHNICAL SPECIFICATIONS

### Measurement range

O <sub>2</sub>	: Default	: [µg/l]	: 0.10 to 2,000
	: Available	: [ppb]	: 0.10 to 2,000
		: [ppm]	: 0.01 to 2.00
		: [%] O <sub>2</sub>	: 0.01 to 4.18
		: [% a.s.]	: 0.01 to 20.0
		: [mg/l]	: 0.01 to 2.00

Temperature	: Default	: [°C]	: -5.0 to 40.0
	: Available	: [°F]	: 23.0 to 104.0

### Accuracy

[ * at 20° C]	: O <sub>2</sub> dissolved	: [ppb]	: ± (1 ppb + 2% of the measured value)
		: [µg/l]	: ± (1 µg/l + 2% of m.v.)
		: [ppm]	: ± (0.001 ppm + 2% of m.v.)
	: O <sub>2</sub> in gas	: [mg/l]	: ± (0.001 mg/l + 2% of m.v.)
		: [% a.s.]	: ± (0.01% a.s. + 2% of m.v.)
		: [%] O <sub>2</sub>	: ± (0.002% O <sub>2</sub> + 2% of m.v.)
Temperature	: [°C]	: Approx. 0.2°C	
	: [°F]	: Approx. 0.4°F	

### Maximum operating pressure

: [barg]	: 10.00 barg
: [psi]	: 145.0 psi
: [kg/cm <sup>2</sup> ]	: 10.20 kg/cm <sup>2</sup>
: [kPa]	: 1,000 kPa

### Maximum cleaning temperature (short duration)

: [°C]	: 60
: [°F]	: 140

## 1.2 INTENDED USE

The Waltron 9065C Portable Luminescent Dissolved Oxygen Analyzer utilizes new luminescent technology for measuring dissolved oxygen in water at ppb levels. Luminescent technology has unique features and benefits compared to traditional dissolved oxygen sensing technologies. The 9065C provides high accuracy with excellent long-term stability. The 9065C Dissolved Oxygen Analyzer can be used in a variety of online analysis applications throughout many different industries.

The 9065C is a portable, rechargeable instrument for measuring the dissolved O<sub>2</sub> content of carbonated drinks and water.

The analyzer can analyze samples from:

- The production process (tanks and pipes)
- Casks
- Full bottles and cans

### **Features:**

- Analysis range: 0.10 ppb – 2000 ppb (other ranges available upon request)
- Lightweight and Portable
- No calibration up to two years
- No sample interferences
- Memory for 400 measurements
- Battery power

### **Benefits:**

- No sensor maintenance (no membrane, no electrolyte)
- Simple and portable operation
- Compact design

## 1.3 SAFETY

### 1.3.1 SYMBOLS

The symbols 'Note:', 'Warning!' and 'Danger' used in this instruction manual have the following meanings.

---

**NOTE:**

Instructions for the correct and effective use of the instrument.

---



---

**WARNING!**

Incorrect or careless use may cause serious damage to the instrument.

---



Incorrect or careless use may place the user or the surroundings in **DANGER**.

---

### 1.3.2 PRECAUTIONARY MEASURES AND SAFETY INSTRUCTIONS

---

**WARNING!**

To avoid a short circuit, never insert metal objects into the connector.

The use of chlorite-based or fluorine-based cleaning products is not permitted. These may cause damage to the instrument.

---



Make sure the 9065C unit is not subjected to external forces.

Make sure the 9065C unit and the power supply are not damaged as a result of a fall.

If these accidents do occur, have the instrument inspected by a certified Waltron technician.

---

## 2 INTRODUCTION

### 2.1 ANALYZER OVERVIEW



**Figure 2.1: Analyzer overview.**

The 9065C has two main sections:

1. Buttons on the top of the instrument
2. Mechanical components:
  - a. The throttle valve
  - b. The two hose sockets for the sample hoses



**Figure 2.2: Control buttons.**

The instrument consists of four parts that are connected to each other

1. The electronics housing
2. The upper housing
3. The battery pack
4. The measurement chamber

## 2.2 O<sub>2</sub> MEASUREMENT PRINCIPLE

The O<sub>2</sub> measurement is based on measuring the luminescence of a layer that is sensitive to oxygen. The luminescence changes according to the partial oxygen pressure. The quantity of dissolved oxygen gas in the liquid is calculated with the aid of the measured partial oxygen pressure and the temperature.

The oxygen sensor optically measures the liquid's O<sub>2</sub> content based on the luminescence measurement principle, where an oxygen-sensitive layer is exposed to blue light. As a result, molecules in the oxygen-sensitive layer are excited.

In the absence of oxygen, the molecules light up red. In the presence of oxygen, the oxygen molecules collide with the molecules in the oxygen-sensitive layer. The molecules that collide with oxygen no longer light up. Through this process, a link is created between the oxygen concentration and both the light intensity and the speed at which the light intensity is reduced. The light intensity reduces when the oxygen concentration is higher, whilst the light intensity reduces at a faster speed.

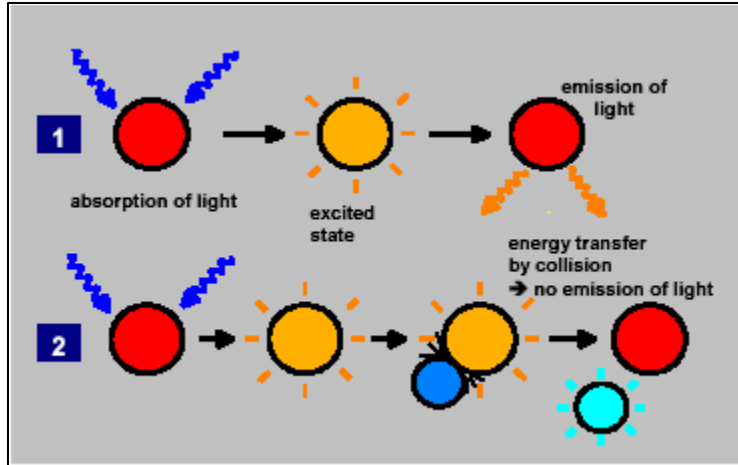

**Figure 2.3: Luminescence in the absence of oxygen (1) and in the presence of oxygen (2).**

The oxygen content is calculated using the time difference between the exposure to the blue light and the molecules lighting up (phase shift) and the product temperature. The sensor in the 9065C is located behind the inlet and before the throttle.

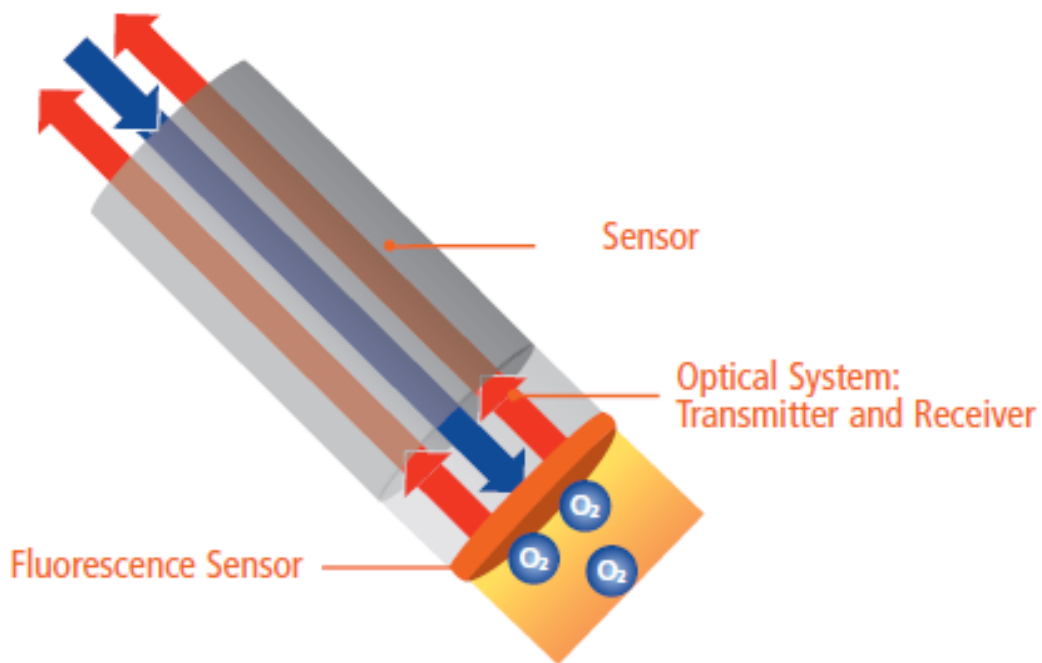

**Figure 2.4: Optical sensor depiction**

## 3 INSTALLATION

### 3.1 CONTENT OF THE DELIVERY

The 9065C is calibrated, checked and tested by Waltron before shipment and the instrument is, therefore, ready for immediate use. It is not necessary to calibrate the instrument again before it is used for the first time.

Check whether the delivery is complete and undamaged. If the delivery is incomplete or damaged, contact Waltron or the Waltron representative in your region immediately (see [www.waltron.net](http://www.waltron.net)). Always state the serial number, the order number or the invoice number (as given by Waltron) of the 9065C in all correspondence.

---

**NOTE:** Before using the instrument, you must make sure the instrument is complete and no parts are missing.

---

The delivery includes:

- The 9065C
- A service set (with tools, replacement parts and a wide range of voltage adaptors)
- A set of hoses
- The PC communication program “DGM utility” on a CD-ROM
- An RS-232 communication cable (1.5 meters)
- Two ID keys for users (optional)
- Two ID keys for locations (optional)
- An instruction manual

Optional extras that can be ordered:

- A quick-charger for users who wish to quickly charge the battery pack. The battery pack must be disconnected from the 9065C while it is being charged.

See Appendix C for a list of other spare parts and components.

### 3.2 PRE-INSTALLATION



Make sure the 9065C is not connected to a sampling point that produces pressures or pressure peaks greater than 10 bar.

---



### 3.3 INSTALLATION

Connect the hoses as described below.

1. Lubricate the O-rings of the hose socket with a small amount of silicon grease (from the service set).
2. Slide the hose connections over the hose sockets of the 9065C until they click into place and then pull them back until they become locked.



**Figure 3.1: O-Ring installation**

### 3.4 UNITS

The units used by the 9065C for the O<sub>2</sub> content and the temperature can be changed. The “Unit” menu is accessed as follows:

1. Press “Enter” for 3 seconds until the Waltron logo is displayed.
2. Besides the software version number, the 9065C serial number is also displayed.
3. Press “Enter” again.
4. The main menu will now be displayed.
5. Use the arrow buttons to select the “Configuration” menu and then press “Enter” to open the menu.



6. Use the arrow buttons to select the “Unit” menu and then press “Enter” to open the menu.
7. The arrow buttons can be used to select the various submenus. Press “Enter” to select the “O<sub>2</sub>” menu, the “Temp” menu or the main menu.
8. The arrow buttons can be used to select the following units:
  - a. Temperature: °C, °F
  - b. O<sub>2</sub> : Dissolved in liquid: ppb; ppm; mg/l; µg/l  
in gas: %; %a.s. (for calibration purposes)
9. Press “Enter” to return to the “Unit” menu.

### 3.5 TIME SETTINGS

Various process times can be set via the “Date/Time/Display” menu. The “Date/Time/Display” menu is accessed as follows:

1. Press “Enter” until the Waltron logo is displayed.
2. Press “Enter” again.
3. The main menu will now be displayed.
4. Use the arrow buttons to select the “Configuration” menu and then press “Enter” to open the menu.
5. Use the arrow buttons to select the “Date/Time/Display” menu and then press “Enter” to open the menu.
5. The arrow buttons can be used to select the various submenus. Press “Enter” to open the “Date” menu, the “Time” menu, the “Shutoff time” menu, the “Display contrast” menu, the “Display times” menu or the main menu.

#### 3.5.1 DATE

The arrow buttons can be used to alter the date. Press “Enter” to go from the day to the month and then to the year. Press “Enter” again to return to the “Date/Time/Display” menu.

#### 3.5.2 TIME

The arrow buttons can be used to alter the time. Press “Enter” to go from the hours to the minutes and then to the seconds. Press “Enter” again to return to the “Date/Time/Display” menu.

#### 3.5.3 SHUT-OFF TIME

The 9065C automatically turns itself off if no buttons have been pressed for a certain time. This time can be adjusted using the arrow buttons. Press “Enter” to return to the “Date/Time/Display” menu.

#### 3.5.4 DISPLAY CONTRAST

The display contrast can be adjusted using the arrow buttons. Press “Enter” to return to the “Date/Time/Display” menu.

### 3.5.5 DISPLAY TIMES

The measured O<sub>2</sub> and temperature values are displayed during every measurement. The arrow buttons can be used to select and alter the display times.

- Press “Enter” to return to the “Display times” menu.
- Select “Main menu” and press “Enter” to return to the main menu.

## 3.6 PRODUCT DEFINITION

The 9065C offers the possibility to define 10 different products that relate to the measurement process times. When the 9065C is delivered, all the products are set to default values. The Products Configuration menu is accessed as follows:

1. Press “Enter” until the Waltron logo is displayed.
2. Besides the software version number, the 9065C serial number is also displayed.
3. Press “Enter” again.
4. The main menu will now be displayed.
5. Use the arrow buttons to select the “Configuration” menu and then press “Enter” to open the menu.
6. Use the arrow buttons to select the “Formula/Prod.Def.” menu and then press “Enter” to open the menu.
7. The product that is selected at that moment will be displayed.
8. The arrow buttons can be used to select the various submenus. Press “Enter” to open the desired menu. The product name and the O<sub>2</sub> sampling time can be defined for each product. The menu is exited by either selecting the “Store product” option to save the changes for each product or by selecting the “Main menu” option to keep the default value.

### 3.6.1 PRODUCT

You can browse through the 10 products and select a product by pressing “Enter”.

While browsing through the products, the settings for the product selected at that moment will be displayed.

You can enter a product name consisting of a maximum of 10 characters. The cursor will move to the next character every time “Enter” is pressed. Once a character has been selected, press the arrow buttons to scroll through the characters. Once the desired character is displayed, press “Enter” to save that character and move to the next character.

The “Product” menu will be displayed again once the last character has been confirmed.

### 3.6.2 O<sub>2</sub> SAMPLING TIME

The time interval of the O<sub>2</sub> measurement and the logging of the measurements in the memory can be set for a continuous O<sub>2</sub> measurement. The default O<sub>2</sub> sampling time is 10 seconds and the adjustment range is 2 to 999 seconds. The measured O<sub>2</sub> values are logged on a PC by means of the software program using the same interval.



## 3.7 LANGUAGE

The language is changed as follows:

1. Press “Enter” until the Waltron logo is displayed.
2. Press “Enter” again.
3. The main menu will now be displayed.
4. Use the arrow buttons to select the “Configuration” menu and then press “Enter” to open the menu.
5. Use the arrows buttons to select the “Language” menu and then press “Enter” to open the menu.
6. You can use the arrow buttons to select Nederlands, Deutsch, English, Francais or Español as the language.
7. Press “Enter” to select a language. The main menu will then be displayed.

## 3.8 ID SYSTEM/PASSWORD

### 3.8.1 PASSWORD

The 9065C has two settings at the user level:

1. “Master User: Present”: All the settings in the 9065C can be changed without limitation. (DEFAULT setting)
2. “Master User: Absent”: You can only select the predefined products, change the time and the display contrast and delete the last measurement. You can view all the other menus but cannot make changes in them.

To switch between the “Master User” options (from “Present” to “Absent” and vice versa), you must enter a password (the default password is 0000).

- If the “Master User” option is set to "Present", then the additional “Password” menu option is displayed with a masked password (\*\*\*\*).
- If you wish to change the password, use the arrow buttons to select the “Password” menu and press “Enter”.
- Enter the old password first and then enter a new 4-digit password. To do so, use the arrow buttons to change the numbers and press “Enter” to move to the next digit.

---

**NOTE:**

If you change the password, remember it or write it in the space below.  
If you lose the password, contact your Waltron representative or contact Waltron directly.

---

You can enter the “Master User” password here:

<b>Password:</b>	
------------------	--

---

## 4 OPERATION

### 4.1 GENERAL INFORMATION

The 9065C has two different measurement programs. One program is for an individual O<sub>2</sub> measurement and the other program is for a continuous O<sub>2</sub> measurement. The desired program can be selected in the “Measurement choice” menu (see Section 4.2).

The instrument must be rinsed with the liquid to be measured before taking the first measurement. The response time of the O<sub>2</sub> measurement is reduced if the instrument is almost the same temperature as the liquid. Rinsing the measurement chambers with the liquid in advance will, therefore, result in a faster measurement. For later measurements, the instrument does not have to be rinsed for so long or it may even not be necessary to rinse the instrument.

Before connecting the 9065C to the sampling point, you must make sure the instrument cannot fall over during the measurement.

- Close the tap on the tank or pipe before the sampling hoses are connected to the 9065C.
- Make sure the throttle valve is not fully closed. The tap must be opened and closed slowly.
- The pressure in the sampling hoses must not exceed 10 bar.

### 4.2 OPERATION PROCEDURE

1. Connect the 9065C sampling hose to the sampling point. Place the end of the outlet hose (9065C) in a drain and secure it in place.

---

**NOTE:** When samples are under low pressure, the instrument must be placed as low as possible. The extra pressure reduces the chance of gas bubbles escaping during sampling.







---

2. Open the tap at the sampling point.
3. Use the throttle valve to adjust the flow rate (approx. 20 l/hour), making sure the throttle valve does not stop the flow of product.

---

**NOTE:** If the throttle valve is fully closed, this will result in an incorrect O<sub>2</sub> value.

---

**Figure 4.1: Flow profile.**

The flow profile on the outlet must be as shown in the bottom figure of the table given above.

There is a bar at the bottom of the display that gives the actual measurement values (see Fig. 4.3 and Fig. 4.4).

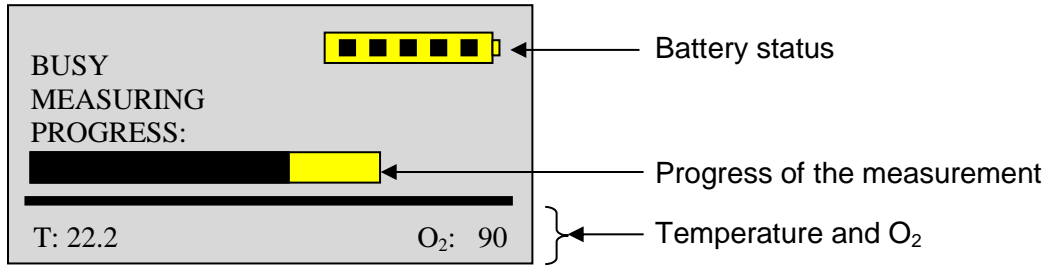

**Figure 4.2: 9065C display during a measurement.**

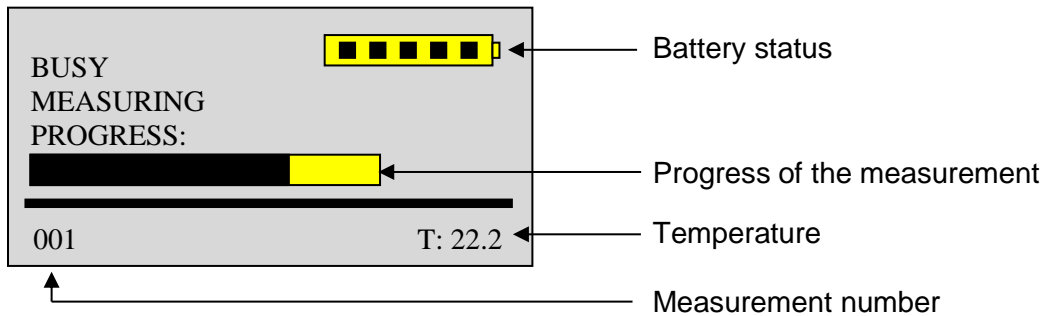

**Figure 4.3: 9065C display during a measurement.**

The bar at the top indicates the battery status. If this bar flashes, you can only carry out a few more measurements with the 9065C before the battery needs recharging.

### 4.3 MEASUREMENT CHOICE

You can select one of the following measurement programs from the “Measurement choice” menu:

1. Individual O<sub>2</sub> measurement.
2. O<sub>2</sub> continuous measurement.

These measurement programs are explained in more detail in the following sections.

The “Measurement choice” menu is accessed as follows:

1. Press “Enter” until the Waltron logo is displayed.
  - Besides the software version number, the 9065C serial number and the oxygen measurement range are also displayed.
2. Press “Enter” again.
  - The main menu will now be displayed.
3. Use the arrow buttons to select the “Measurement choice” menu and press “Enter” to open the menu.
4. Use the arrow buttons to select one of the measuring programs that are displayed.

### 4.3.1 O<sub>2</sub> MEASUREMENT

An O<sub>2</sub> measurement using the 9065C consists of the following processes: taking an oxygen measurement and displaying the measured O<sub>2</sub> value and the measured temperature. The display times for the oxygen content and the temperature can be set in the “Display times” menu.

Before the measurement, the product-specific parameters can be set in the “Product choice” menu.

The figures below show the sequence of displays for a measurement:

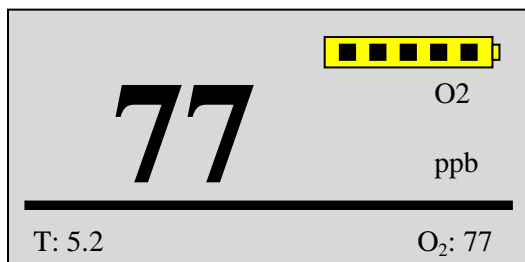

**Figure 4.4: Oxygen content display.**

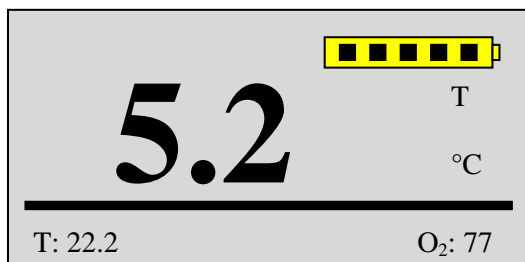

**Figure 4.5: Display during a temperature measurement.**

As soon as the last samples have been measured, the 9065C must be rinsed with cold water. Store the 9065C either empty or filled with water.

### 4.3.2 O<sub>2</sub> CONTINUOUS MEASUREMENT

With this measurement, the oxygen content is measured continuously while the liquid flows through the 9065C. This option is typically used to check processes where there is a chance of oxygen getting into the liquid, such as during filtration or when switching tanks.

The measurement is started as follows:

1. Use the throttle valve to slow down the flow in order to reduce the amount of product.
2. Press “Enter” for approximately 1 second.
  - The continuous oxygen measurement will be started and the current measurement value will be displayed. The measurement values will be saved in the 9065C based on the set O<sub>2</sub> sampling time.



- If the battery is fully charged, continuous oxygen measurements can be taken for approximately 8 hours.
3. The continuous oxygen measurements can be stopped by pressing “Enter”.

#### 4.4 READING THE MEASUREMENT RESULTS

**Procedure:**

1. Press “Enter” for approximately 3 seconds.
  - The input menu will be displayed.
2. Press “Enter” again.
  - The main menu will be displayed.
3. Use the Down arrow button to select “Logbook” in the main menu and press “Enter”.
4. Select “Results” in the logbook menu and press “Enter”.
5. The measurement results can now be read. To select a different measurement, scroll up or down through the measurement numbers.
6. Press “Enter” to return to the main menu.

#### 4.5 DELETING MEASUREMENT RESULTS

**Procedure:**

1. Press “Enter” for approximately 3 seconds.
  - The input menu will be displayed.
2. Press “Enter” again.
  - The main menu will be displayed.
3. Use the Down arrow button to select “Logbook” in the main menu and press “Enter”.
4. Select “Delete all results” in the “Logbook” menu and press “Enter”.
5. The main menu will then be displayed.

#### 4.6 PRODUCT CHOICE

The 9065C allows you to easily set product-specific settings.

The predefined products can be selected from the “Product choice” menu before a measurement is carried out or they can be programmed in the key for the place ID.

The “Product choice” menu is accessed as follows:

1. Press "Enter" until the Waltron logo is displayed.
2. Press “Enter” again.
  - The main menu will now be displayed.
3. Use the arrow buttons to select the “Product choice” menu and press “Enter” to open the menu.
4. Use the arrow buttons to scroll to one of the products and press “Enter” to select the product and to return to the main menu.

## 4.7 CHARGING THE BATTERY

The battery level bar is divided into 5 blocks. They are all visible when the battery is fully charged. When the battery level bar shows a remaining charge of less than 20%, the battery pack must be recharged.

When 20% is remaining, the battery still has enough charge to carry out several measurements before the display turns off and no more measurements are possible.

Procedure:

1. Remove the protective cover from the charging/communication connector.
2. Insert the charger's plug into the connection at the rear of the 9065C.
3. Connect the charger to the mains power.
  - While charging, the battery level bar moves to show that the battery is being charged.
4. Disconnect the 9065C from the charger after approximately 6 hours.
5. Refit the protective cover to the back of the 9065C.

If the battery is completely discharged, it takes approximately 6 - 8 hours to recharge the battery pack using the charger. The 9065C has an internal regulator to control the charging process and to protect the battery against overcharging. The battery is also protected against overheating, so the 9065C can be recharged for an unlimited time. However, the lifespan of the battery will be increased if the recharging time is limited to 24 hours or less.

---

**WARNING!**

The charging connector at the rear of the 9065C must never be open when the 9065C is not connected to the charger. Always place the protective cover on the connector when the charging cable is disconnected.

---

To avoid a short circuit, never insert metal objects into the "SFE".

---

**NOTE:**

The battery pack has a limited lifespan (see Section 7.2).

---

### Quick-charger (optional)

A quick-charger is available as an optional extra and can be used to charge the battery pack separately.

Procedure:

1. Use the tools from the service set to remove the battery pack's two attachment screws at the rear of the instrument.
2. Remove the battery pack horizontally from the 9065C.
3. Connect the quick-charger to a plug socket.
  - The LED on the quick-charger will be lit red.
4. Connect the quick-charger to the connector inside the battery pack.

- The LED will be lit orange.
5. The battery pack will be charged within 2 to 3 hours.
    - The LED will be lit green once the charging process has been completed.
  6. Disconnect the battery pack from the quick-charger and unplug the quick-charger from the plug socket.
  7. Reinsert the battery pack into the 9065C and tighten the screw.

**Table 4.1: Charge cycle and LED indications on the quick-charger.**

LED	Mode
Off	Not connected to the mains power supply.
Yellow	Mains power supply connected, but the battery is not connected or battery initialization and analysis.
Orange	Quick charging.
Green with flashing yellow	Intermediate mode with top-off charge.
Green	Trickle charge.
Orange-green flashing light	Error: Battery charge below the normal level. Charging stopped. The battery pack must be reconnected.

---

**NOTE:** Wait at least 15 seconds before connecting another battery. This will allow the quick-charger to reset itself.

---

## 5 CALIBRATION AND COMPENSATION

### 5.1 CALIBRATION OF THE TEMPERATURE SENSOR

The temperature sensor is a precision component that does not require calibration. The temperature sensor can be checked by allowing a flow of liquid through the measurement chamber unit and comparing the temperature displayed on the 9065C to a reading from an accurate thermometer placed in the product outlet flow of the 9065C.

### 5.2 CALIBRATING THE O<sub>2</sub> SENSOR

Since the oxygen sensor only experiences a very slight amount of wear as a result of exposure, regular calibration is not necessary. It has been empirically determined that after 1 million exposures (equal to 1 million O<sub>2</sub> measurements), the O<sub>2</sub> deviation from the zero point is just 5 ppb and that at higher O<sub>2</sub> values, no deviation is detectable.

There is a light pulse counter integrated in the software, which counts the number of light exposures. When 1 million exposures have taken place, the warning “Calibrate or replace the O<sub>2</sub> sensor” will be displayed and the sensor must be calibrated or replaced. The warning symbol will be displayed as a reminder.

After successfully calibrating the sensor, the light pulse counter will be reset and the warning symbol will no longer be displayed.

The following two principle methods are described to calibrate the oxygen sensor:

1. One point calibration
  - This method is recommended if a high accuracy for higher oxygen concentration is required.
2. Calibration with two gasses
  - This method is recommended to ensure the specified accuracy over the whole oxygen measuring range.

#### 5.2.1 CALIBRATION FREQUENCY

Assuming a rate of 500 measurements per day, 7 days a week, 52 weeks a year, the sensor must be calibrated once every five years.

A monthly check of the zero point is recommended (also as a result of ISO procedures) and can easily be performed by:

- Flushing the 9065C with a class 5 CO<sub>2</sub> or N<sub>2</sub> calibration gas.
- Filling the 9065C with a zero-point liquid without O<sub>2</sub>, such as a sodium sulfite solution (Na<sub>2</sub>SO<sub>3</sub>; 2%).

The temperature of the 9065C and the sodium sulfite solution/calibration gas must not deviate by more than 1.5°C.

**NOTE:** A sodium sulfite solution has to be stored in a closed bottle due to the consumption of O<sub>2</sub>.

If an O<sub>2</sub> deviation of > 1 ppb is observed, then a zero-point calibration is recommended.

### 5.2.2 ONE POINT CALIBRATION

For most applications in the low oxygen measuring range a calibration of the zero point is sufficient.

To do so follow the instruction as given for the calibration with two gasses. The atmospheric pressure and the calibration of the high concentration do not have to be entered again. Therefore, skip point 9 from Section 5.2.3.

### 5.2.3 CALIBRATION WITH TWO GASES

#### Preparation:

- Extra requirements: Barometer with an accuracy of 1 mbar.
- Both the zero point and a high calibration point can be calibrated with a defined oxygen concentration. The calibration gases must be dry.
- The zero-point calibration should be carried out using a gas with a certified oxygen content of  $\leq 0.001\%$ . We recommend the use of nitrogen or carbon dioxide with a purity of 99.9990% (Class 5.0). The high calibration point for the sensor must be calibrated with an accuracy of  $\pm 1\%$  using a gas with a certified oxygen content of up to 4%. N<sub>2</sub> or CO<sub>2</sub> with 4% or 1% O<sub>2</sub> can be used for this.
- The inside of the 9065C must be dry during calibration with a gas. Rinse the 9065C for approx. 15 minutes with N<sub>2</sub> or CO<sub>2</sub> or oil-free compressed air. During the calibration process, the % unit or the % a.s. unit must be used. Since the oxygen sensor measures the oxygen partial pressure, the oxygen content measured in the gas during the calibration process depends on the atmospheric pressure.
- The manually entered atmospheric pressure in the “P-atm” parameter in the “Calibration” menu is taken into consideration when determining the oxygen content in the % O<sub>2</sub> unit and the % a.s. unit.

**NOTE:** Only flush the 9065C using low gas flow speeds. Use a reduction valve while flushing the 9065C with compressed air or a calibration gas and adjust the flow to 30 l/h with the aid of a flow meter.

**NOTE:** For an accurate O<sub>2</sub> calibration or gas inspection, the 9065C must be at the same temperature as the gas. To achieve this, leave the 9065C and the calibration gas bottles filled with water for approx. 12 hours at room temperature.



**Procedure:**

1. Press the “Enter” button for at least 3 seconds.
  - The Waltron menu is shown.
2. Press the “Enter” button.
  - The main menu is shown.
3. Use the down arrow button to select the “Calibration” menu and press the “Enter” button.
4. Select “O<sub>2</sub> calibration” and press the “Enter” button.
5. Select “Calibration” and press the “Enter” button.

```

WALTRON
V02.04 SER.NO. : 30000
    
```

6. The “Sensor type” is shown.
  - The LHO sensor is suitable for a measuring range of 0 to 2 ppm

```

O2 CALIBRATION

CALIBRATION
FIXED CALIBRATION

MAIN MENU
    
```

7. Select “P-Atm”, press the “Enter” button, and the cursor jumps to the value after the parameter “P-Atm”.
  - a. Now read the atmospheric pressure in the calibration room.
  - b. Set the actual atmospheric pressure during the oxygen calibration. You can change the value with the up and down arrow buttons and accept the value with the “Enter” button.
  - c. When all the values have been set, press the “Enter” button: the value is now accepted and parameter “Zero point” is automatically selected.
  - d. The option “P-ATM” appears only if the 9065C is set to the oxygen units % or %a.s.. In this case the set atmospheric pressure is taken into account while displaying the oxygen value.

```

CALIBRATION

SENSOR TYPE : LHO
O2 ACT.      :0.010 %
TEMP ACT.    :21.3 °C
P-ATM.       :1.013 BAR
ZERO POINT   :0.000 %
O2 HIGH      :4.000 %
    
```

```

CALIBRATION

SENSOR TYPE: LHO
O2 ACT.      :0.010 %
TEMP ACT.    :21.3 °C
P-ATM.       :1.013 BAR
ZERO POINT   :0.000 %
O2 HIGH      :4.000 %
    
```

8. Retract the handle and connect a zero-point liquid/gas that contains no O<sub>2</sub> to the inlet of the 9065C. Let the zero gas slowly (max. 30 l/h) flow through the 9065C until the current oxygen value no longer changes (Cur. O<sub>2</sub>). Make sure that the 9065C is dry internally and the throttle valve is open far enough to prevent extra pressure from building up.
  - a. Press the “Enter” button to calibrate the zero point. The values measured during several seconds will be checked for stability of the oxygen signal.
  - b. When the signal value of the oxygen sensor is not stable, the following message appears: “O<sub>2</sub> sensor values unstable. Recal. meas. point” In this case, the zero point must be recalibrated.
  - c. The parameter “O<sub>2</sub> high” is automatically selected.

CALIBRATION	
SENSOR TYPE:	LHO
O <sub>2</sub> ACT.	:0.010 %
TEMP ACT.	:21.3 °C
P-ATM.	:1.013 BAR
<b>ZERO POINT</b>	<b>:0.000 %</b>
O <sub>2</sub> HIGH	:4.000 %

9. Now connect a calibration gas with a known oxygen content to the inlet of the 9065C. For the sensor this can be CO<sub>2</sub>/N<sub>2</sub> with 4% O<sub>2</sub> and an accuracy of ± 1%. Allow the gas to continue flowing slowly through the 9065C (max 30 l/h) until the current oxygen value no longer changes (Cur. O<sub>2</sub>). Make sure the throttle valve is open far enough to prevent the build-up of extra pressure.
  - a. Use the arrow buttons to set the oxygen value of the calibration gas; use the “Enter” button to move to the next digit.
  - b. After the last digit, press the “Enter” button to calibrate the high calibration point. The values measured during several seconds will be checked for stability of the oxygen signal. “Store Calibration” is selected automatically.
  - c. If the signal from the oxygen sensor is not stable the following error message will appear: “O<sub>2</sub> sensor values are unstable. Recal. meas. point.” In this case, the zero point must be recalibrated.
  - d. The menu point “O<sub>2</sub> sensor constants” is automatically selected.

CALIBRATION	
SENSOR TYPE:	LHO
O <sub>2</sub> ACT.	:3.993 %
TEMP ACT.	:21.3 °C
P-ATM.	:1.013 BAR
ZERO POINT	:0.000 %
<b>O<sub>2</sub> HIGH</b>	<b>:4.010 %</b>

10. Press the “Enter” button to set the O<sub>2</sub> sensor constants

CALIBRATION	
P-ATM.	:1.013 BAR
ZERO POINT	:0.000 %
O <sub>2</sub> HIGH	:4.010 %
<b>O<sub>2</sub> SENSOR CONSTANTS</b>	
STORE CALIBRATION	
MAIN MENU	



11. In case the O<sub>2</sub> sensor has been exchanged, fill in the values for the O<sub>2</sub> sensor constants given on the calibration certificate.
  - a. Use the arrow buttons to enter the digits and the “Enter” button to move to the next digit.
  - b. After the last digit, press the “Enter” button to proceed to the next menu point.
  - c. Select the menu point “Previous Menu” to return to the calibration menu.

```

O2 SENSOR CONSTANTS
C1: + 0,86469
C2: - 0,03803
C3: + 0,00852
C4: + 28,98344

PREVIOUS MENU
    
```

12. Press the “Enter” button to save the calibration. If the calibration completes successfully, the 9065C software program will return to the “main menu”, otherwise you will receive the message: “Questionable calibration, old calibration restored”

```

CALIBRATION
P-ATM.      :1.013 BAR
ZERO POINT :0.000 %
O2 HIGH    :4.010 %
O2 SENSOR CONSTANTS
STORE CALIBRATION
MAIN MENU
    
```

13. You can also leave the “Calibration” menu without storing the calibration by selecting the “Main menu” option and pressing the “Enter” button.

```

CALIBRATION
P-ATM.      :1.013 BAR
ZERO POINT :0.000 %
O2 HIGH    :4.010 %
O2 SENSOR CONSTANTS
STORE CALIBRATION
MAIN MENU
    
```



## 6 CLEANING AND MAINTENANCE

### 6.1 DAILY CLEANING

The 9065C must be rinsed with cold water every day after use.

To rinse the 9065C, connect the inlet hose to a cold water tap and rinse the instrument with the throttle valve open. If a very sticky liquid has been measured, a special cleaning process with a cleaning agent, as described in 6.2.1, must be carried out regularly in order to prevent the build-up of deposits.

Store the instrument in a cool location with the throttle valve open.  
The temperature of the storage location must not be less than 0°C/32°F.

### 6.2 MONTHLY MAINTENANCE

---

**NOTE:** Maintenance must be carried out by personnel who are familiar with the applicable maintenance regulations.

---

#### 6.2.1 SPECIAL CLEANING

When traces of contamination remain after thorough cleaning, the instrument must be partially filled with a suitable cleaning solution.

To do so:

1. Connect the hoses to the instrument.
2. Pour the cleaning liquid into the inlet through a funnel until the liquid flows out of the outlet. Collect the cleaning liquid that escapes in a suitable container.
3. It is also possible to carry out a short CIP cleaning flush. Leave the cleaning liquid in the 9065C so that the oxygen sensor on the instrument's inlet and the outlet are also cleaned by the cleaning solution.



**Wear suitable protection against chemicals and pay special attention to hot cleaning agents.**

---

Suitable cleaning agents are:

- Base cleaning agents with an alkali concentration of 0.5% - 2% (NaOH) that are intended for use at room temperature.
- Depending on the degree of contamination, the required cleaning time will vary from 15 minutes to several hours.
- When completed, open the throttle valve and rinse the instrument with clean water.



- When there are salt deposits in the instrument (beer stone), the instrument must also be cleaned at room temperature as described above using an acidic cleaning agent with a nitric acid base (~ 0.5%) or a phosphoric acid base (~ 2%).
- Once completed, the instrument must be rinsed with cold water. Do not use cleaning agents that contain chlorite or fluorine.

After rinsing, make sure no traces of the cleaning agent remain in the system. Insufficient rinsing can lead to corrosion under the O-rings.

Recommended alkali cleaning agents:

- Divo Schaum ML      Diversey
- P3-F                      Henkel
- Kinray D                Reddish Savilles
- Fett-Löser              Dr. Becher

Recommended acidic cleaning agents:

- Dilac R                    Diversey
- P3 Horolith 283        Henkel
- P3 Trimeta S Special    Henkel

## 6.2.2 THROTTLE VALVE CHAMBER

### Procedure:

1. Unscrew the throttle valve all the way out of the measurement chamber unit.
2. Use the O-ring puller from the service set to remove the O-ring from the throttle valve.
3. Clean the throttle valve.
4. Use the brush from the service set to scrub the throttle valve with a cleaning solution and then rinse it thoroughly with water.
5. Replace a damaged O-ring . Make sure the O-ring's sealing surface is not damaged! Only use O-rings from the service set. Several O-rings are included in the service set.
6. Lightly lubricate the throttle valve and the O-ring with the silicon grease from the service set.
7. Carefully refit the throttle valve into the housing.

## 7 TROUBLESHOOTING AND REPAIR

### 7.1 TROUBLESHOOTING LIST

Problem	Cause	Solution
Nothing is displayed on the screen when a button is pressed.	The batteries are discharged.	Recharge the battery pack.
The temperature measurement gives HHH or LLL.	The measurement value is outside of the measurement range. LLL indicates the value is too low. HHH indicates that the value is too high.	The electronic connection to the main electronics has been broken. Contact your local representative or Waltron.

Error message	Cause	Solution
Battery voltage too low. Measurement aborted.	The battery is discharged.	Charge the battery.
Charging voltage too high. Check adaptor.	The power supply has the wrong voltage.	Check the power supply.
A measurement is not possible during charging of the battery.	For safety reasons, you cannot carry out any O <sub>2</sub> measurements whilst the battery pack is being charged.	Charge the battery pack and then disconnect the power supply.
Questionable calibration. Old calibration restored.	The difference between the measured oxygen signal at the zero point and at the high calibration point is too small.	Check if gases with different O <sub>2</sub> concentrations are being used during the calibration. Use a calibration gas with a higher O <sub>2</sub> content.
O <sub>2</sub> sensor - calibrate or replace symbol on the display 	The maximum number of exposures has been reached and the oxygen sensor deviation at the zero point is 5 ppb.	Calibrate or replace the oxygen sensor.
O <sub>2</sub> sensor values are unstable.	The set oxygen content was not stable during the calibration.  You are trying to calibrate the sensor at an oxygen concentration level that is in excess of its measurement range.  The oxygen sensor measurement signal is unstable.	Recalibrate this calibration point and make sure the oxygen value is stable before carrying out the calibration.  Use a calibration gas that lies within the oxygen sensor's measurement range.  Contact your local representative or Waltron.
O <sub>2</sub> value is outside measurement range.	The measured oxygen content is too high or too low.	Check whether you are measuring within the sensor's measurement range. If you are within the measurement range, recalibrate the oxygen sensor.



## 7.2 REPLACING THE BATTERY PACK

The battery pack must be replaced if the capacity of the battery pack declines to the point that only a few measurements can be carried out before the battery must be recharged. Under normal circumstances, a battery can undergo approximately 500 charge/discharge cycles.

### Procedure:

1. Use the socket screw key (4 x 100) from the service set to remove the attachment bolt. Pull the battery pack out of the back of the 9065C.
2. Remove the battery pack.
3. If necessary, clean and dry the back of the top block.
4. Fit the new battery pack, making sure the push-pull connectors are positioned correctly. Use the Allen screw to screw the battery pack into the top block at right angles. Do not over tighten the Allen screw.
5. If necessary, charge the battery pack.

---

**NOTE:** The old battery pack must be sent to an appropriate waste disposal organization or can be returned to Waltron (Also see the text on the battery pack).

---

## 7.3 REPLACING THE O<sub>2</sub> SENSOR

The replacement set for the oxygen sensor includes a new sensor, O-rings and a special screwdriver.

### Procedure:

1. Rinse the 9065C via the outlet with gas to dry it.

---

**WARNING!** If there is still liquid in the measurement chamber unit, this liquid may get into the electronics when the unit is removed.

---

2. Place the 9065C upside down on a soft, sturdy surface to prevent the components from becoming scratched.
3. Use the socket screw key from the service set to unscrew the 6 screws.
4. Remove the protective housing from the measurement chamber unit by first detaching it near the hose sockets.
5. Use the special screwdriver from the oxygen sensor set to unscrew the 4 screws.
6. Carefully pull the measurement chamber unit straight out of the 9065C. Put the 9065C aside so that the PT100, which protrudes from the bottom, is not damaged.
7. Push the oxygen sensor from the bottom upwards out of the measurement chamber unit.

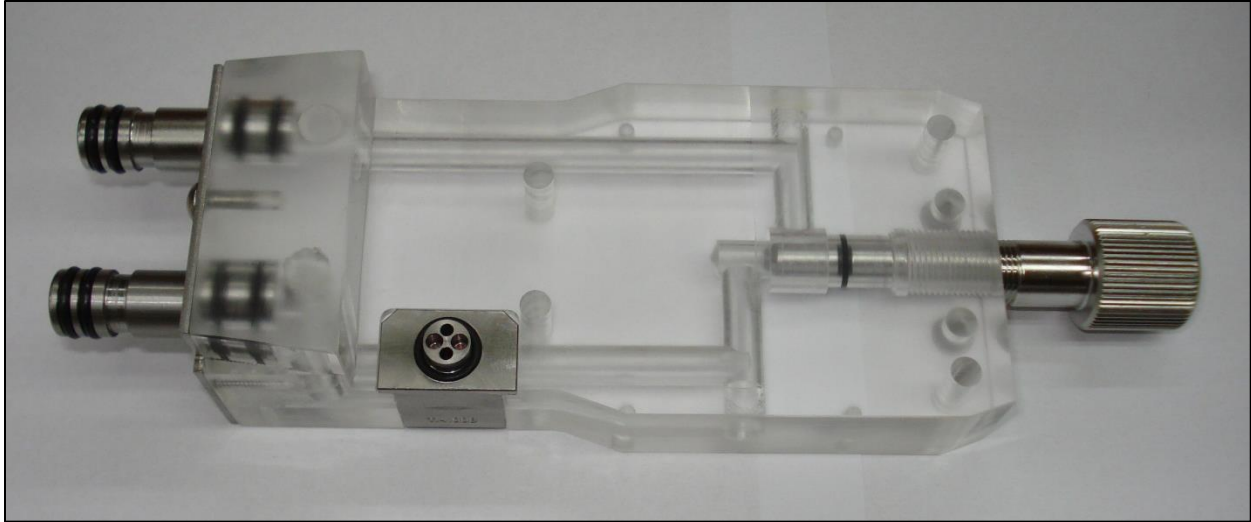

**Figure 7.1: Measurement chamber unit.**

8. Fit the two new O-rings from the oxygen sensor set in the O-ring grooves in the new oxygen sensor and lightly lubricate the O-rings with silicon grease (from the service set).
9. Press the new oxygen sensor into the measurement chamber unit from the top until it touches the stop and fit the O-ring at the top.
10. Carefully fit the measurement chamber unit and the new oxygen sensor into the 9065C so that the light guide and the PT100 (temperature sensor) in the top block fall into the hole opposite to the oxygen sensor. For the best temperature measurement, fit the PT100 using heat conducting paste.

---

**NOTE:** All the O-rings must be positioned correctly to properly seal the top block.

---

11. Use the special screwdriver from the oxygen sensor set to tighten the 4 screws crossways.
12. Fit the protective housing back on to the measurement chamber unit.
13. Use the socket screw key from the service set to tighten the 6 screws.

## 8 DEACTIVATING, STORAGE AND TRANSPORT

### 8.1 DEACTIVATING

If the 9065C is no longer used, the components must be sent to an appropriate waste disposal organization or the entire unit can be returned to Waltron. The materials from which the main components are made are given below:

**Table 8.1: Main component materials.**

PCB housing	metal plate, electronics and sensors, ABS
Top chamber	Perspex
Measurement chamber unit	Perspex, ABS, stainless steel
Battery unit	batteries (NiMH), Polyurethane, stainless steel plate

### 8.2 STORAGE

The instrument must be stored in a dry location and be protected against mechanical and/or chemical damage. If the 9065C is not going to be used for a long time, the instrument must be thoroughly rinsed with water to clean it. The instrument must then be emptied, flushed with air and dried.

The 9065C must be completely empty (dry) when it is stored away.

### 8.3 TRANSPORT

When the 9065C is transported, the display and the Perspex components must be protected against direct mechanical impact. We recommend saving the packaging materials provided by Waltron and using them whenever the 9065C is transported.

The 9065C must be completely empty (dry) when it is transported.

## 9 SPARE PARTS

If you order spare parts, we kindly request you to include all the information given below.

- Serial number of the 9065C
- Description
- Part number

**Table 9.1: Spare Parts Listing.**

<b>Description</b>	<b>Part No.</b>
Set of high-pressure hoses 6 x 12 mm (standard)	K5000-035
Set of o-DGM O-rings	K5000-050
Battery pack	K5000-070
Cap	K5000-071
O-ring cap	K5000-051
O-ring grease 100g	K5000-052
Software set	By Request
CD-ROM with PC communication program "DGM utility"	By Request
RS-232 cable (1.5 metre)	By Request
RS-232 adapter 9 pin male / 25 pin female	By Request
Set of high-pressure hoses 6 x 12 mm with metal connection (optional)	K5000-038
O <sub>2</sub> sensor set (0 to 2 ppm) from o-DGM	K5000-078
Support bracket (handle)	K5000-036
Film of the o-DGM display	By Request
Throttle valve	K5000-079
Screw M3 x 8	K5000-060
Screw M4 x 10	K5000-061
Screw M5 x 40	K5000-062
Screw M5 x 30	K5000-063
Silica gel	K5000-072



---

Key 2 x 100	K5000-073
Key 4 x 100	K5000-074
O-ring puller	K5000-053
Brush	K5000-075
Calibration bolt (hollow)	K5000-076
Cloth	K5000-077



## APPENDIX A: FORMULAS

### Converting the temperature units:

$$\text{Temperature } T (^{\circ}\text{C}) = (T (^{\circ}\text{F}) - 32) \cdot 5/9$$

### Conversion of O<sub>2</sub> units:

The 9065C can be set to various oxygen units, where the instrument then makes the following conversions:

$$\%O_2 = \% \text{ air saturation} \cdot \frac{20,95}{100}$$

With

$T_m$  : Temperature in  $^{\circ}\text{C}$

$p_{atm}$  : Atmospheric air pressure during the oxygen calibration (bar).

$$c_T = \left( 48,998 - 1,335 \cdot T_m + 0,02755 \cdot T_m^2 - 0,000322 \cdot T_m^3 + 0,000001598 \cdot T_m^4 \right)$$

temperature correction

$$\frac{mg}{l} = p_{atm} \cdot \frac{\% \text{ air saturation}}{1013} \cdot \frac{0,2095}{100} \cdot c_T \cdot \frac{32}{22,414}$$

$$ppm = \frac{mg}{l}$$

$$\frac{\mu g}{l} = \frac{mg}{l} \cdot 1000 = ppb$$



## APPENDIX B: SOFTWARE STRUCTURE

